

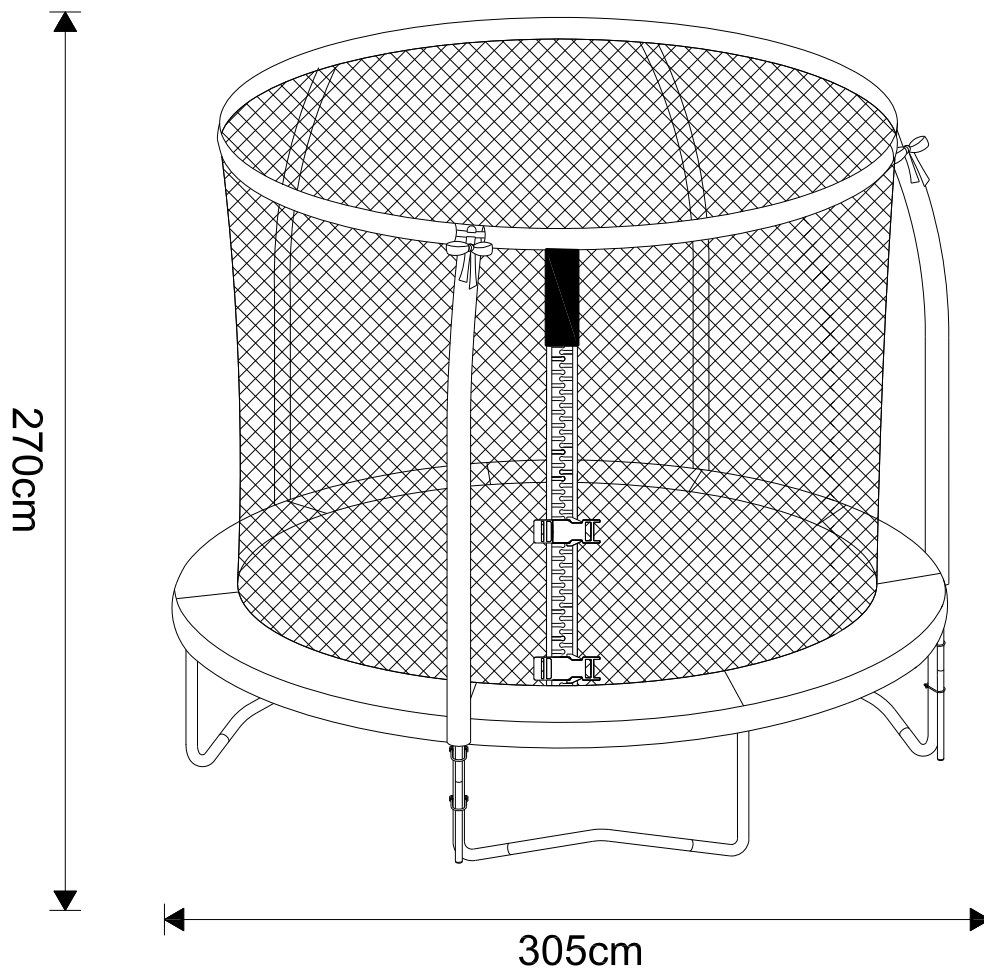

Assembly Instruction Trampoline – Extreme 305



It is very important that you read and understand the instructions before assembling and using the trampoline.

We hope that you will enjoy using the trampoline. A trampoline is great fun and at the same time good exercise. It takes some time to assemble so please read all the instructions before starting and it will be easier. It is possible that the assembly will take more than an hour, so be patient and get the assistance of a friend.

IMPORTANT

Read the following statements and warnings to avoid serious or fatal injury.

Warning!

- Max 150 kg.
- Only for domestic use.
- Outdoor use.
- Only one user. Collision hazard.
- The net should be replaced every year.
- Adult supervision required.
- Do not perform somersaults (flips). This is very dangerous and you risk serious injury or death.
- Always close the safety net opening before jumping.
- Read the instructions.
- The trampoline shall be assembled by an adult in accordance with the assembly instructions and then checked before the first use.
- Jump with proper gym shoes or barefoot only.
- Empty pockets and hands before jumping.
- Always jump in the middle of the mat.
- Do not use when the mat is wet.
- Do not eat while jumping.
- Do not exit by a jump.
- Limit the time of continuous usage (take regular breaks).
- Do not use in strong wind conditions and secure the trampoline.
- Do not try to jump over the net.
- Do not purposely jump onto the net.
- Do not try to purposely rebound off the safety net.
- Do not hang on the top of the net, or try to climb the netting.
- Take off any jewellery that could become entangled with the netting or cut the netting.

Placement of the trampoline

Do not place the trampoline on a concrete floor or other hard surfaces. The ideal placement is a level, stable surface like a lawn. There must be at least 2 meters of space around the trampoline. Check that there are no wires, tree branches, fences or other possible hazards above and around the trampoline. The trampoline should not be placed near any pools, swings, slides, climbing frames or other obstructive installations. The trampoline is not intended to be buried into the ground.

Weather conditions

The trampoline should not be used when wet. In winter conditions, please disassemble the trampoline and store all fabric parts (mat, foam pad, safety net) inside. In strong wind conditions, disassemble the foam pad and safety net and secure the trampoline to the ground using Ground Stakes/Anchors (sold separately).

How to use

Take it easy at first. Don't try difficult moves.

Do not jump when tired - this increases the risk of injury. Be sure to wear proper shoes, e.g. gym shoes, or be barefoot when jumping.

Never step on the frame pad. It is not constructed to support the weight of a person. Never dismount by jumping off the trampoline. Always climb off. Don't use the trampoline under the influence of drugs or alcohol.

Always have someone else watching while you jump. If you should injure yourself you will have someone to assist you.

Always start your jump at the centre of the mat. If you land more than 30 cm away from the edge of the logo, stop your jump immediately!











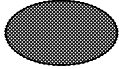

Restart your jump at the centre of the mat.

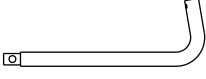
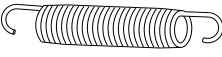
Assembly





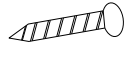







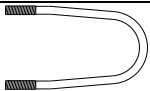

Please read the assembly instructions fully before starting to assemble the trampoline. It is advisable to have two people assembling it together.

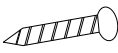
Start first by checking that you have all the required parts. The reference No. of each part will be used in the instructions to guide you.

TRAMPOLINE Parts List

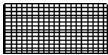
Parts No.	Parts	Description	Quantity
1		Trampoline Mat, stitched with Triangle-Rings	1
2		Frame Pad	1
3		Top Rail with Leg Sockets	4
4		Top Rail	4
5		Leg Base	4
6		L-Shaped Leg	8
7		Galvanized Springs (3,2mm x 28N)	56
8		Spring Loading Tool	1
9		Arc Washer	8
10		Screw	8
11		Allen Wrench	1
12		Spring Washer (Large)	8
13		Self-Locking Screw	8
14		Spring Washer (Small)	8

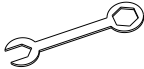
ENCLOSURE Parts List

Parts No.	Parts	Description	Quantity
A		Upper Frame Tube with Long Foam	4
B		Middle Frame Tube with Long Foam	4
C		Lower Frame Tube with No Foam	4
D		U-Screw	8
E		Clamp	8
F		Lock Nut	16
G		Gap Spacer	8
H		Self-Locking Screw	12
I		Cable Wire	8
J		Spring Washer (Small)	8
K		Plastic Cap	4
L		Cap	4
M		Enclosure Netting	1
N		Cord	6
O		End Cap	4
P		Wrench	1
Q		PVC Sleeve	4

Trampoline assembly

Two people required for assembly.

STEP 1

Start by building the frame. Slide the pieces together. Begin by laying out the pieces as shown in the picture.

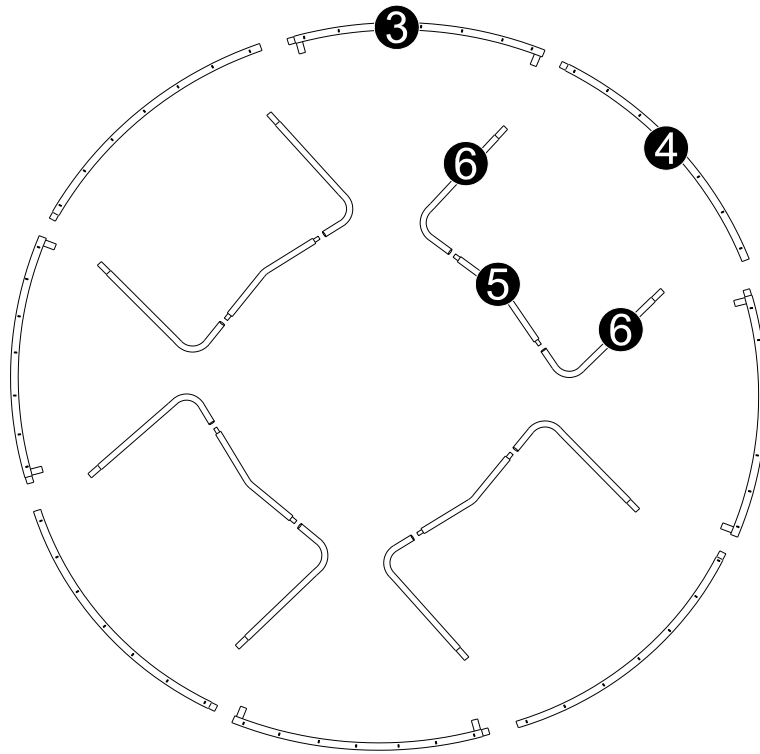

STEP 2

Slide two "L-shaped Legs" ⑥ into the "Leg Base" ⑤ as shown. Repeat this step for all the Leg Bases. Secure with the "Screw" ⑩, "Spring Washer (Large)" ⑫ and "Arc Washer" ⑨.

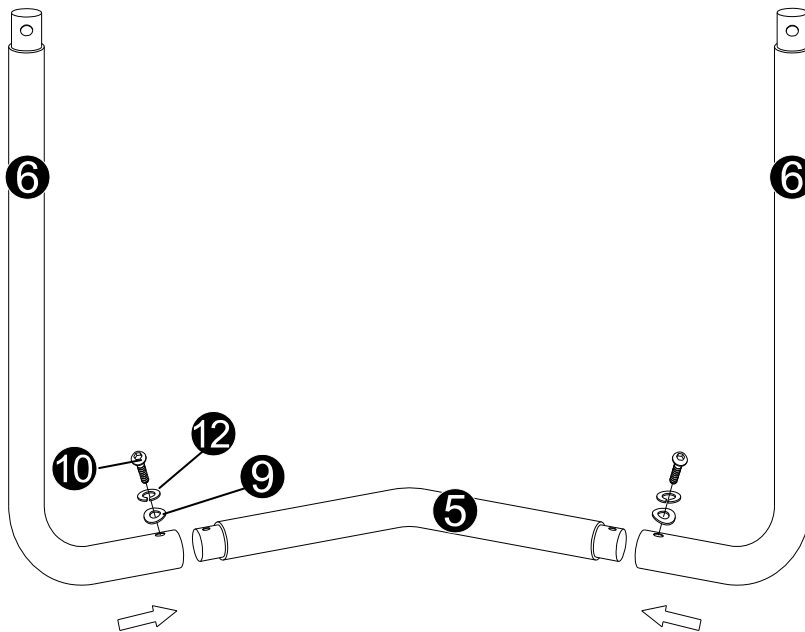

STEP 3

Take the leg support built in step 2. This part will be simpler if one person holds the leg support and another person puts the “Top Rail with Leg Sockets” ③ in place as shown. Repeat for all legs.

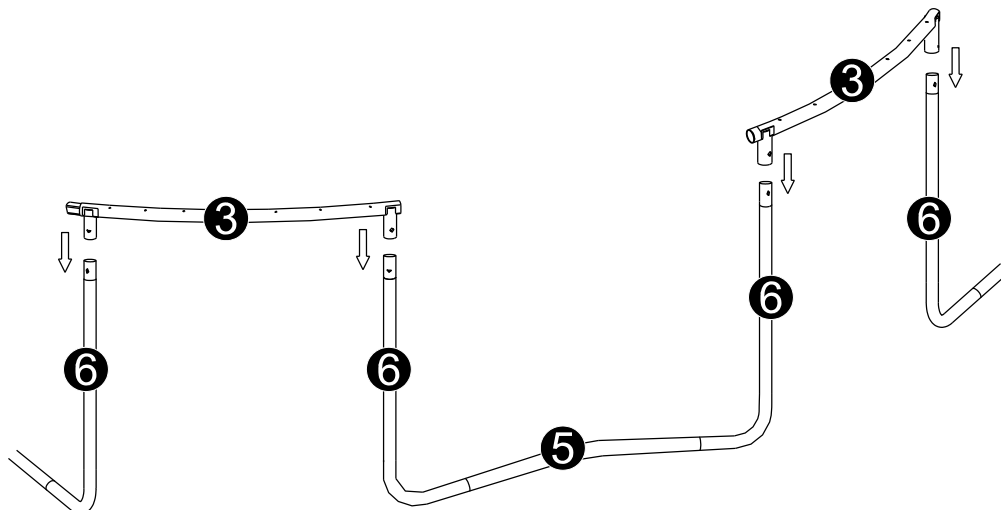

Now insert the remaining “Top Rail” ④ into the spaces between leg supports as shown.

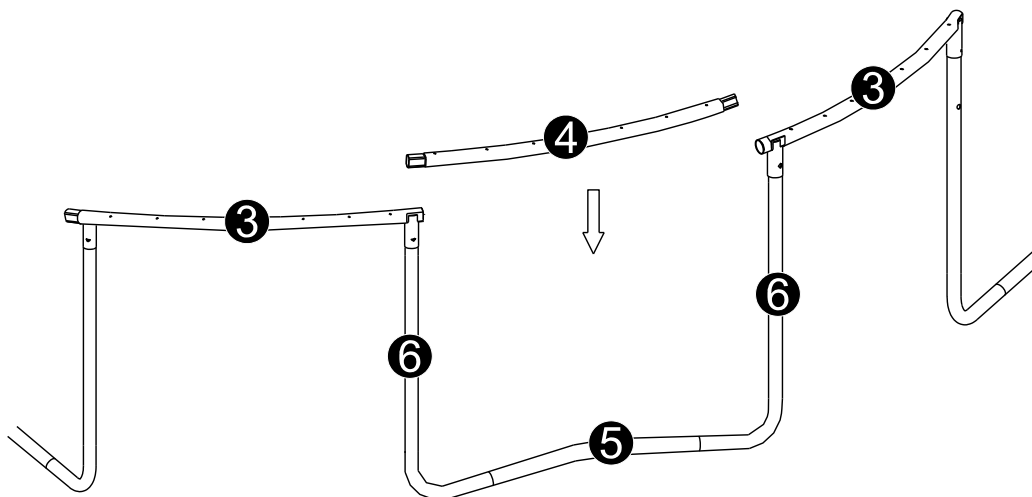

Screw in the “Self-Locking Screw” ⑬ and “Spring Washer (Small)” ⑭ as shown. Do not tighten fully at this point.

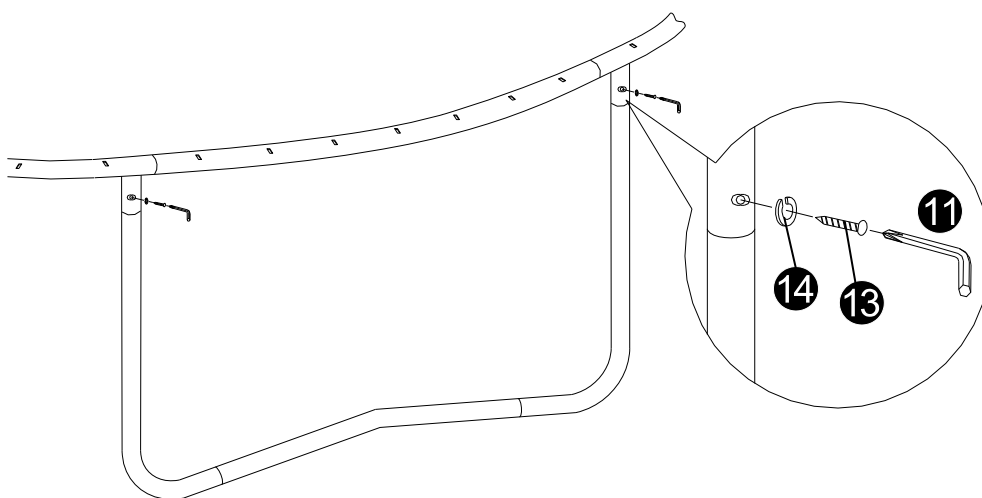

STEP 4

Please take care when attaching the springs.

Start by laying out the "Trampoline Mat" ① inside the frame.

Select a point to start. Call this 1. Use the special spring tool to attach the "Galvanized Springs" ⑦ as shown.

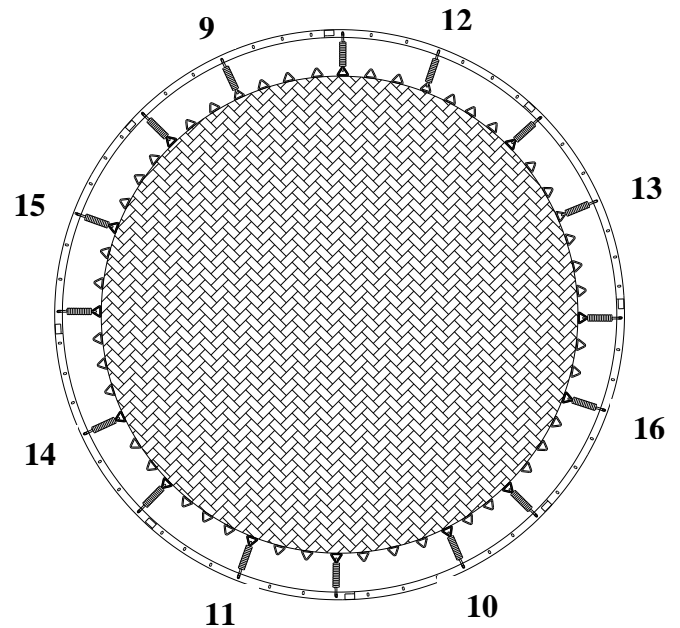
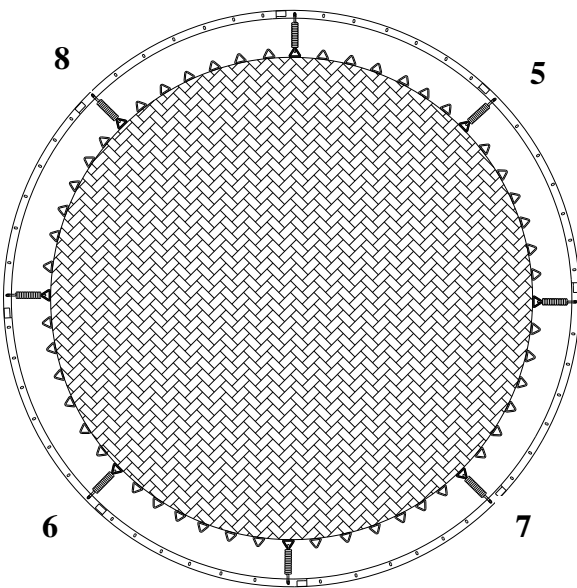
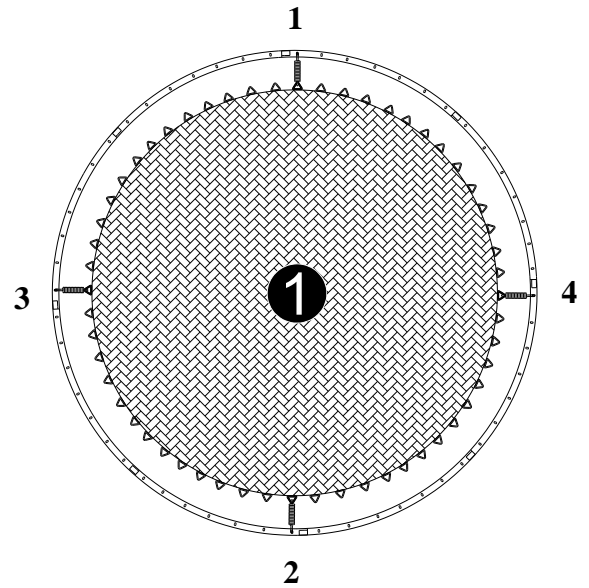
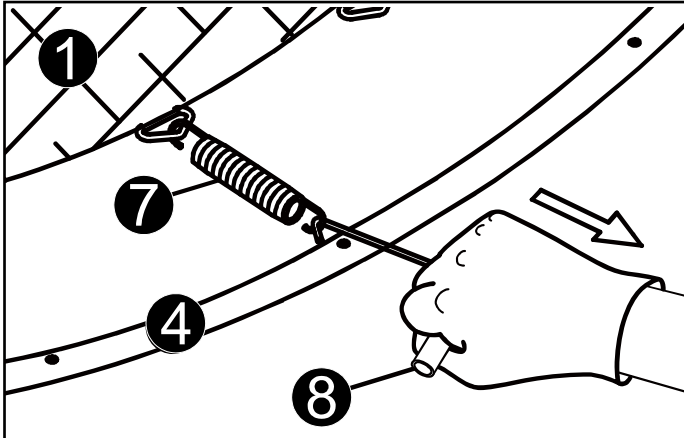

Start by putting the hook of the spring in the V-shaped ring on the trampoline mat. Then use the special tool to pull the spring into place on the frame. Make sure that the spring hooks on completely otherwise it may come loose during jumping. When doing this you should wear protective gloves to avoid injuries.

When the first spring is in place continue with the next in the numerical order shown on the picture. When you have completed number 16 you can attach the remaining springs in any order. It is important to follow this instruction carefully to get the right tension for the trampoline mat. If you do not follow this pattern it will be very difficult to assemble the trampoline mat correctly.

STEP 5

Lay the "Frame Pad" ② over the trampoline so that it covers the springs and the metal frame. Line up the straps so that you have one over the leg sockets and one between. Make sure to tie the straps tightly. Tie the straps as shown.

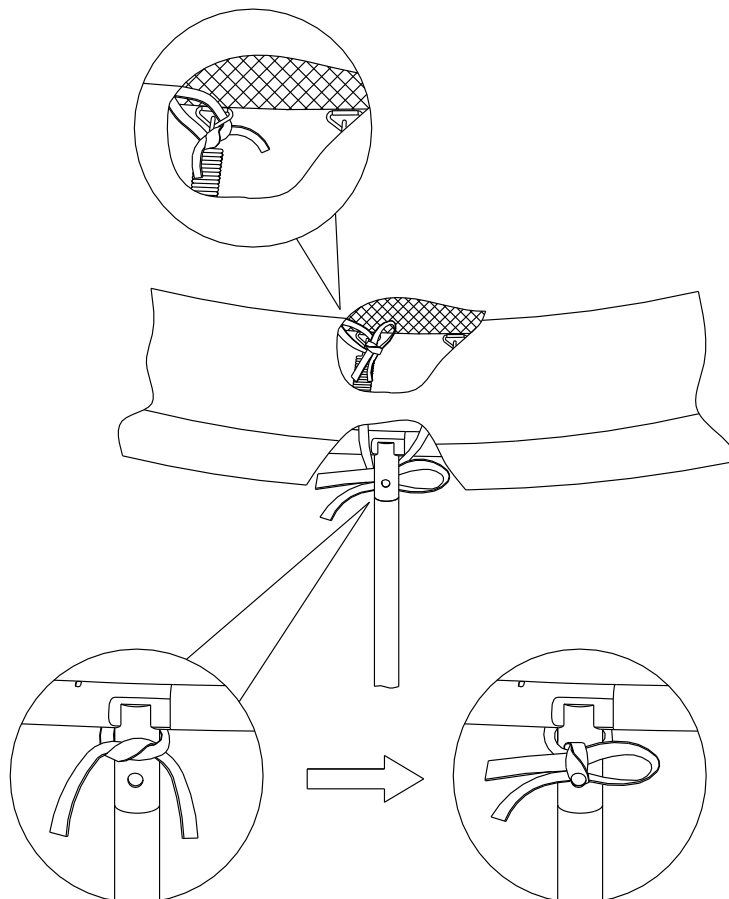
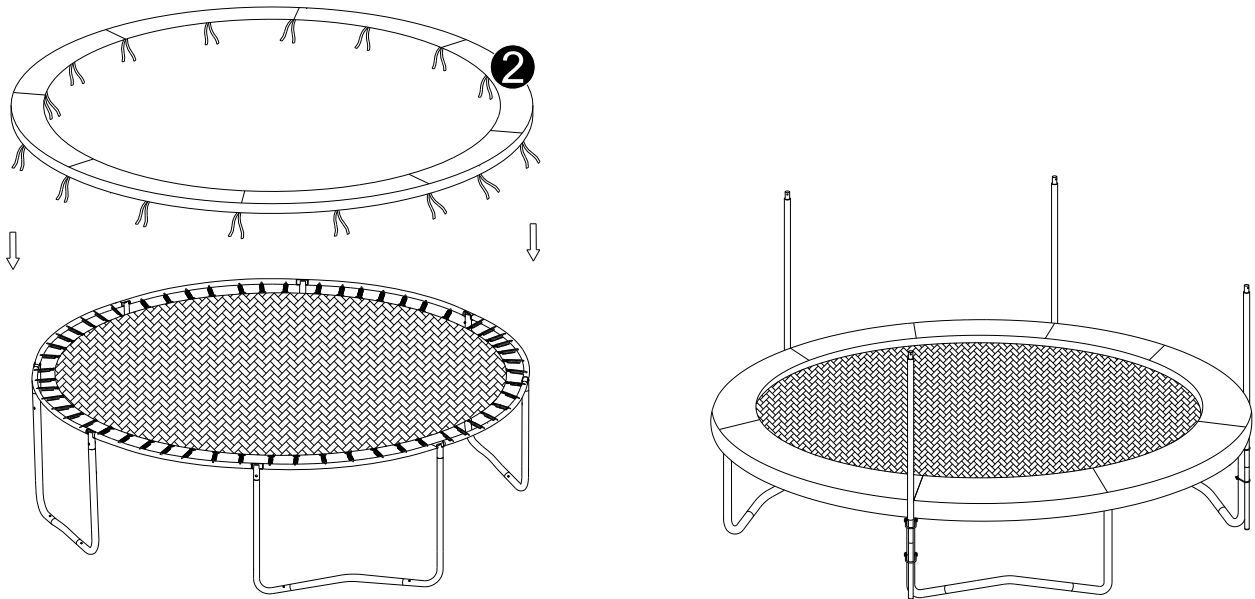

Now go back and tighten all screws firmly on the trampoline.

Enclosure assembly

Two people required for assembly.

STEP 6

Attach "End Cap" **(D)** to the "Lower Frame Tube with No Foam" **(C)** making sure it is fitted at the correct end as shown.

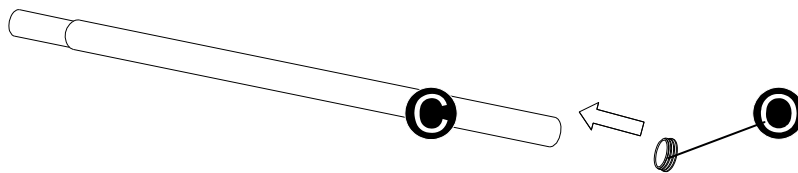

Attach the "Lower Frame Tube with No Foam" **(C)** to the leg frame, using the "U-screw" **(D)**, "Gap Spacer" **(G)** and secure with the "Clamp" **(E)** and the "Lock Nut" **(F)** as shown. Hint: Don't tighten all lock nuts at once. Tighten all the lock nuts at the end of Step 7.

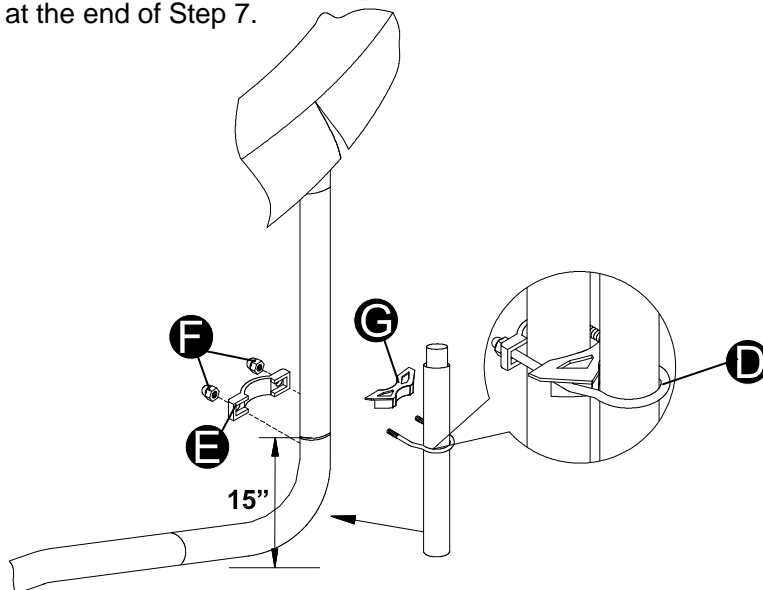

STEP 7

Attach the "Middle Frame Tube with Foam" **(B)** to the "Lower Frame Tube with No Foam" **(C)**. Screw in the "Self-Locking Screw" **(H)** and "Spring Washer (Small)" **(J)** as shown. Do not tighten fully at this point.

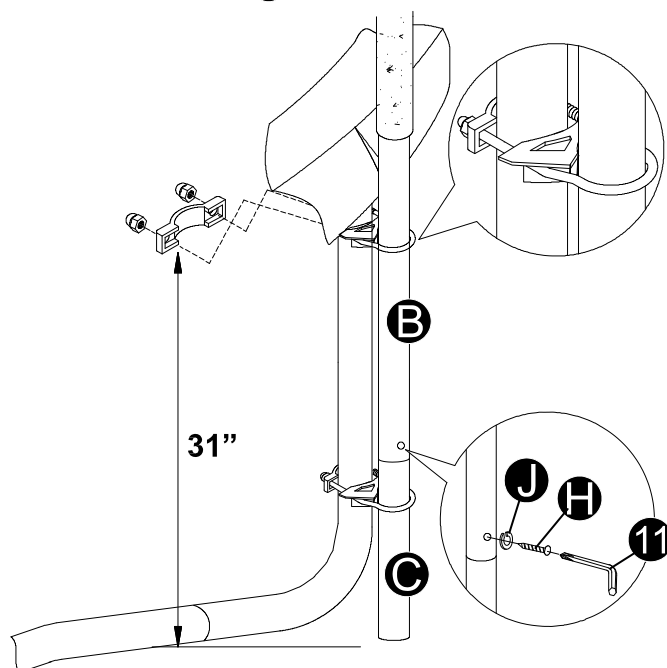

Repeat step 1 and 2 for all frame tube sets and tighten all the nuts.

STEP 8

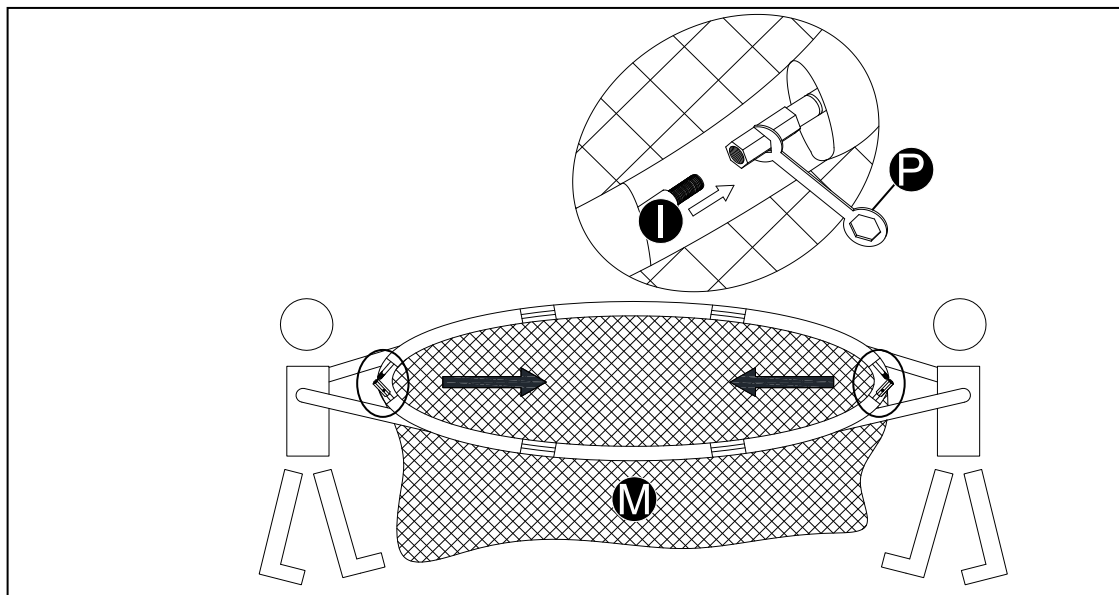
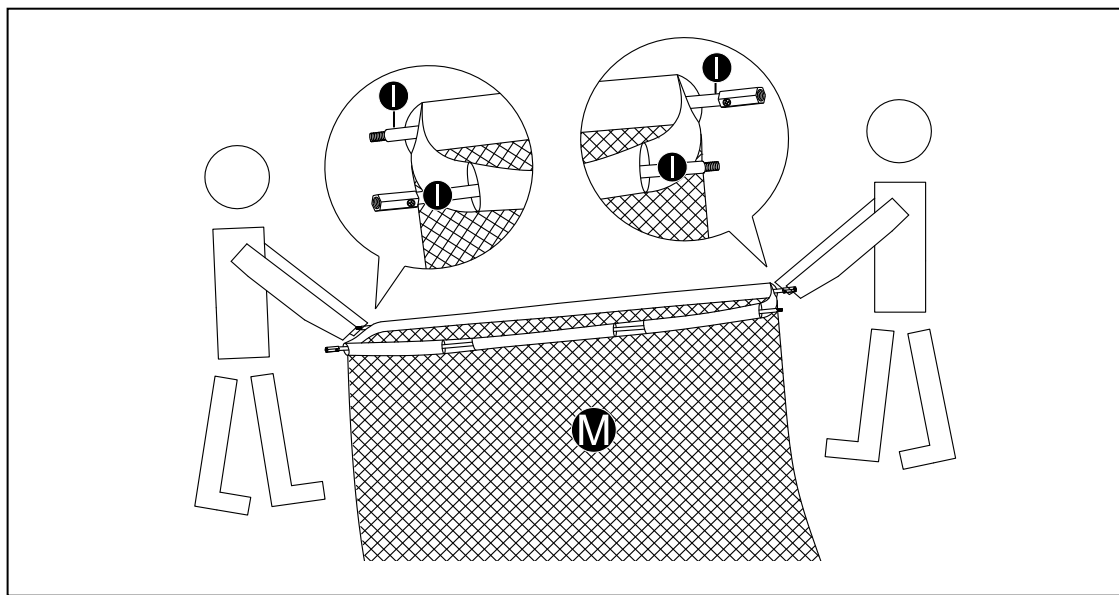
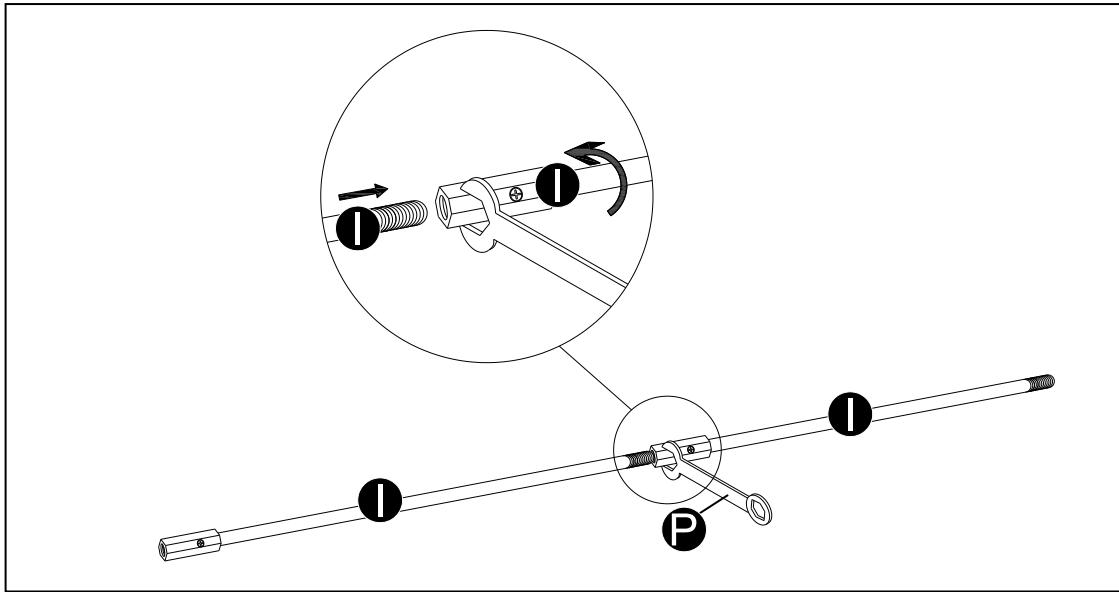

STEP 9

Pull the foam down slightly to locate the hole on the curved end of “Upper Frame Tube with Long Foam” **A** . Attach the “Plastic cap” **K** and secure with the “Self-Locking Screw” **H** .

Slide in “PVC Sleeve” **Q** into “Upper Frame Tube with Long Foam” **A** . Please make sure the tie on the upper part of the Sleeve is on the top. Secure the top opening of the Sleeve with a tie.

Then slide the Cable Wire in to the “Plastic Cap” **K** assembled on the Upper Frame Tube with Long Foam **A** . Make sure the cable wire fits into the slot properly. Pull down the PVC Sleeve **Q** to cover up all the foam as shown.

Finally, put the ” Cap” **L** onto the “Plastic Cap” **K** .

Repeat for all tubes.

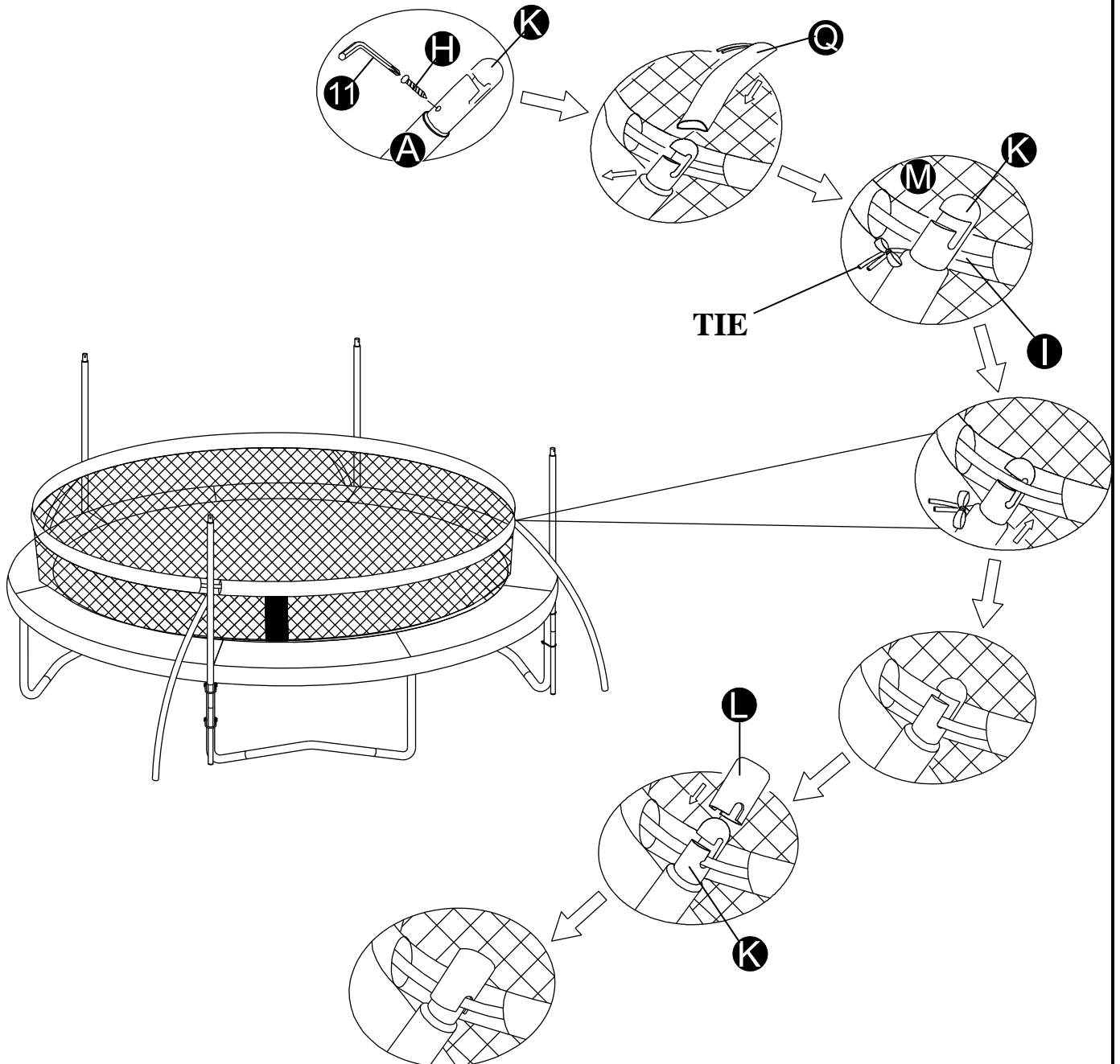

STEP 10

Now lift the assembled “RING” up to attach the “Upper Frame Tube with Long Foam” **A** to the “Middle Frame Tube with Long Foam” **B** .

Make sure all legs are in place before securing with the “Self-Locking Screw” **H** and “Spring Washer(Small)” **J** .

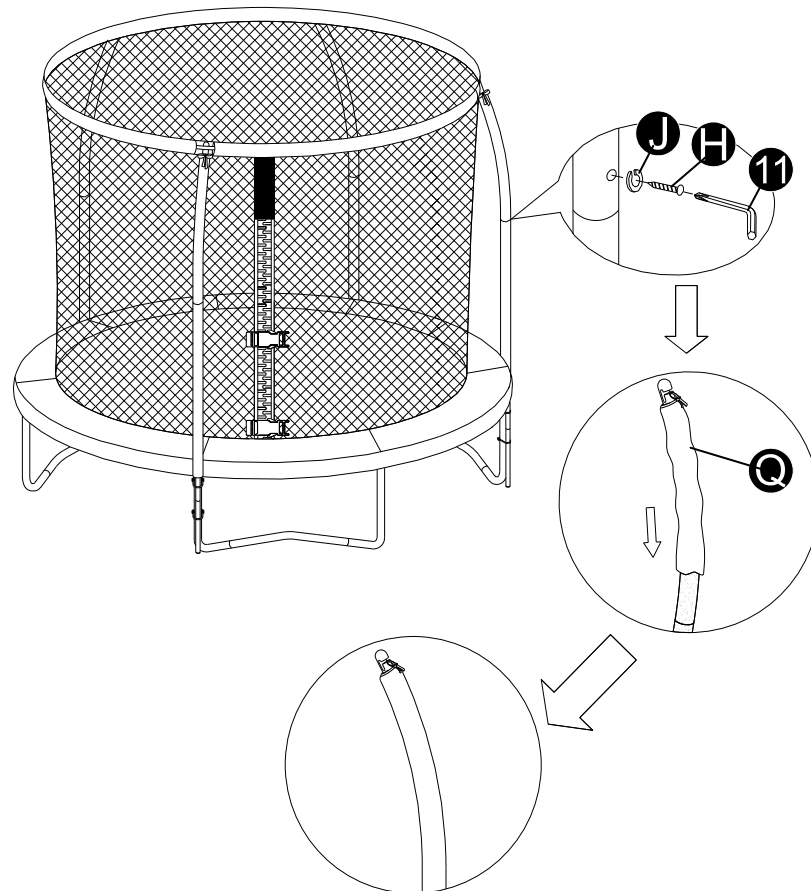
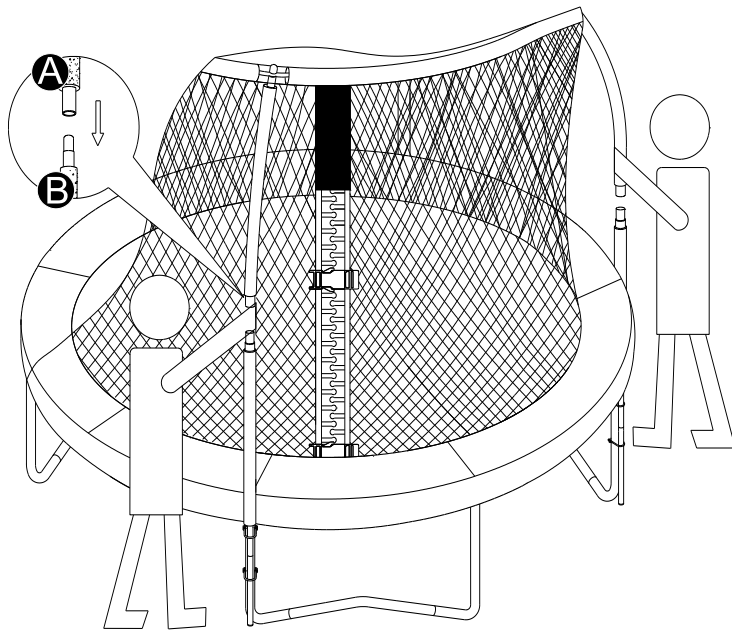

STEP 11

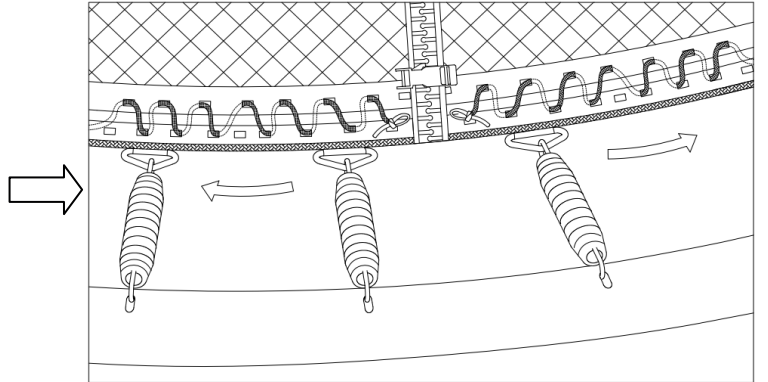
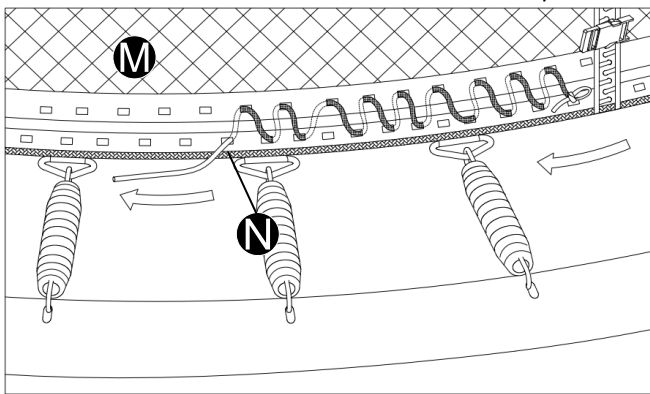
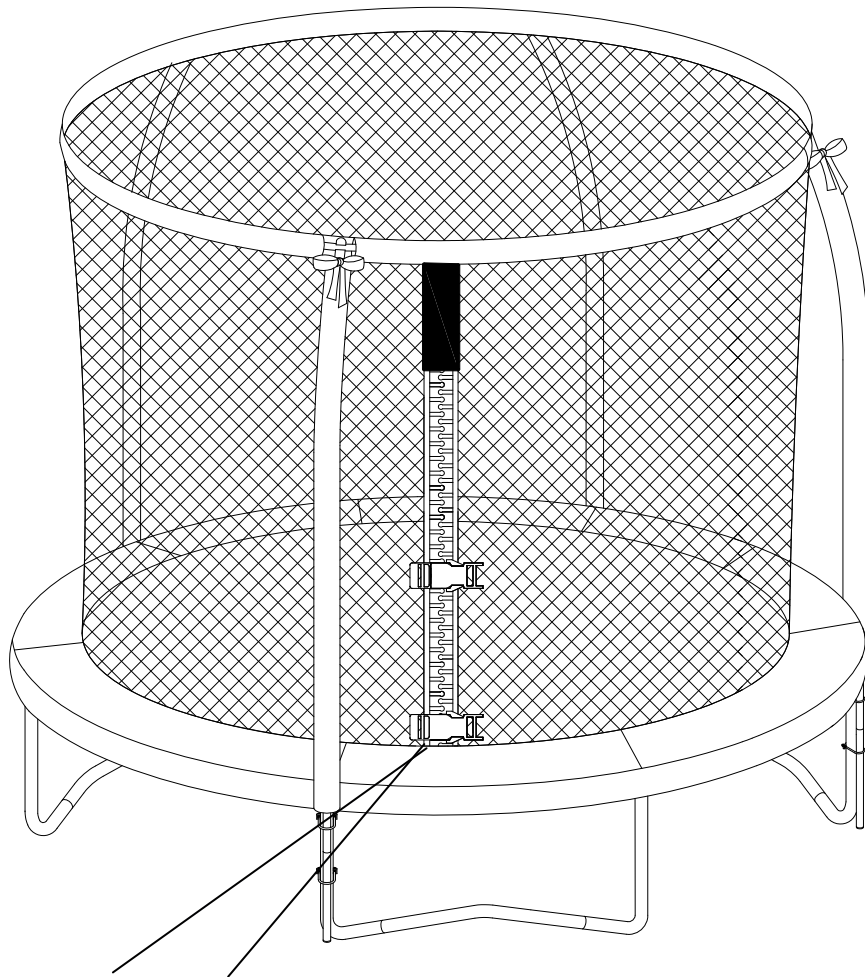

STEP 12

Pull the zip of the "Netting" **M** at the door which should be located within one leg base of the Trampoline, then snap the two buckles together as shown.

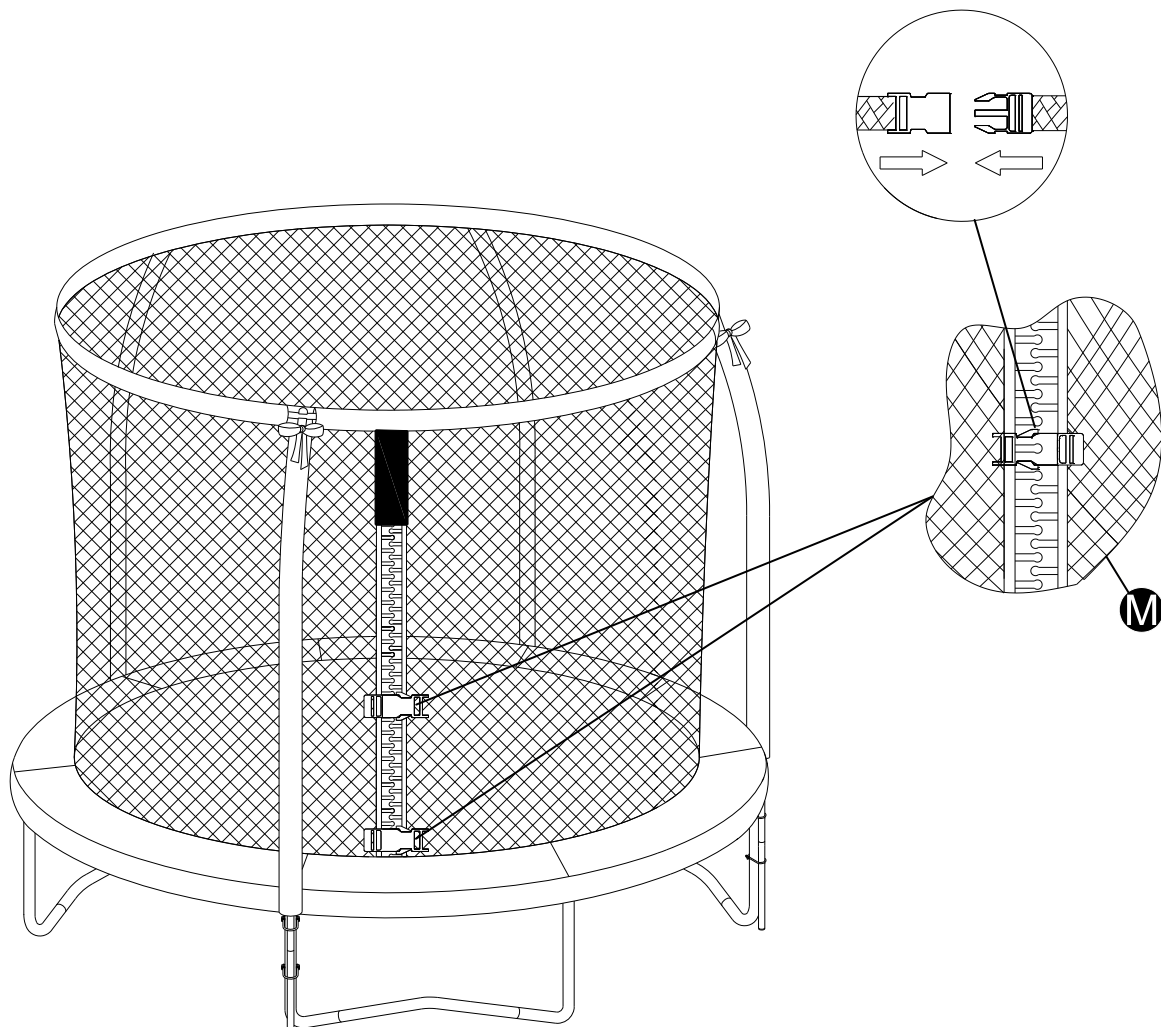

STEP 13

Important: Remember to go back and tighten all screws, nuts and buckles on both the Trampoline and the Enclosure Netting. Otherwise it may not function properly and may lead to injuries that could have been avoided by proper assembly.

The assembly of the trampoline is now complete. Remember to be careful when jumping.

BASIC TRAMPOLINE BOUNCES

THE BASIC BOUNCE

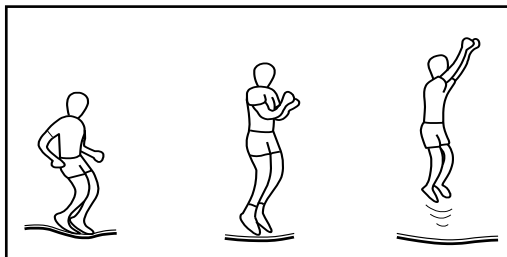

1. Start from standing position, feet shoulder width apart and with head up and eyes on mat.
2. Swing arms forward and up and around in a circular motion.
3. Bring feet together while in mid-air and point toes downward.
4. Keep feet shoulder width apart when landing on mat.

KNEE BOUNCE

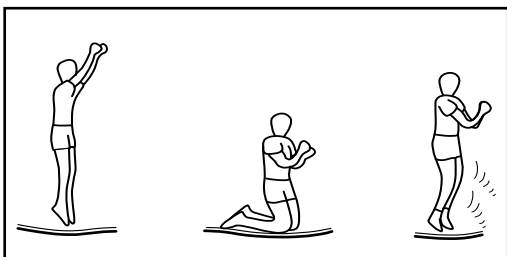

1. Start with basic bounce and keep it low.
2. Land on knees keeping back straight, body erects and uses your arms to maintain balance.
3. Bounce back to basic bounce position by swinging arms up.

SEAT BOUNCE

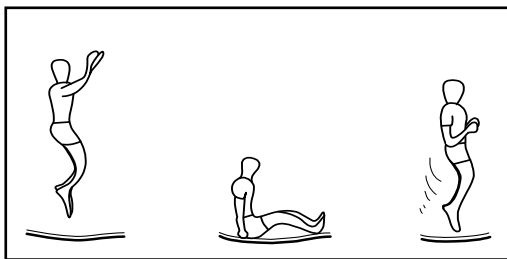

1. Land in a flat sitting position.
2. Place hands on mat besides hips, do not lock your elbow.
3. Return to erect position by pushing with hands.

FRONT BOUNCE

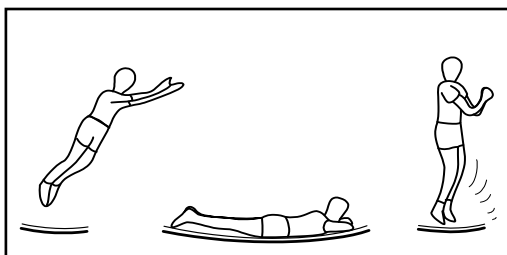

1. Start with a low bounce.
2. Land in prone (face down) position and keep hand and arms extended forward on mat.
3. Push off the mat with arms to return to standing position.

180 DEGREE BOUNCE

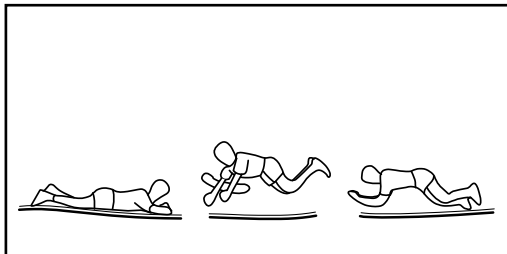

1. Start with front bounce position.
2. Push off with left or right hands and arms (depending on which way you wish to turn).
3. Maintain head and shoulders in the same direction and keep back parallel to mat and head up.
4. Land in prone position and return to standing position by pushing up with hands and arms.

WARNING:

ALWAYS START YOUR JUMP AT THE CENTER OF THE MAT. WHEN YOU LAND MORE THAN 30 CM AWAY FROM THE LOGO, STOP YOUR JUMP IMMEDIATELY! RESTART YOUR JUMP AT THE CENTER OF THE MAT.

NOTE:

MAKE SURE ALL BUCKLES AND ZIPPERS ARE CORRECTLY CLOSED DURING ANY USE OF THE TRAMPOLINE.

CARE AND MAINTENANCE

This trampoline was designed and manufactured with quality materials and craftsmanship. If proper care and maintenance is provided, it will provide all jumpers with years of exercise, fun, and enjoyment as well as reduce the risk of injury. Please follow the guidelines listed below. Installments of additional accessories must be carried out as per manufacturer's instructions.

This trampoline is designed to withstand a certain amount of weight and use. Please make sure that only one person at any one time uses the trampoline. Jumpers should either wear socks, gymnastics shoes, or be barefoot when using the trampoline. Please be aware that street shoes or tennis shoes should NOT be worn while using the trampoline. In order to prevent the trampoline mat from getting cut or damaged please do not allow any pets onto the mat. Also, jumpers should remove all sharp objects from their person prior to using the trampoline. Any type of sharp or pointed objects should be kept off the trampoline mat at all times. Regularly check that nuts and bolts are securely tightened, since they may come loose over time. Check that all spring-loaded (pit pin) joints are still intact and cannot become dislodged during play; Check all coverings and sharp edges and replace when required Check that mat, padding and enclosure are free from defects.

Always inspect the trampoline before each use for worn, abused or missing parts. A number of conditions could arise that may increase your chances of getting injured. Please be aware of:

- Punctures, holes, or tears in the trampoline mat
- Sagging trampoline mat
- Loose stitching or any kind of deterioration of the mat
- Bent or broken frame parts, such as the legs
- Broken, missing, or damaged springs
- Damaged, missing, or insecurely attached frame pad
- Protrusions of any types (especially sharp types) on the frame, springs, or mat

Note. Sunlight, rain, snow and extreme temperatures reduce the strength of these parts over time.

IF YOU FIND ANY OF THE PREVIOUS CONDITIONS, OR ANYTHING ELSE THAT YOU FEEL COULD CAUSE HARM TO ANY USER, THE TRAMPOLINE SHOULD BE DISASSEMBLED OR SECURED FROM USE UNTIL THE CONDITION (S) HAS BEEN RESOLVED.

Do not modify the trampoline or any of its parts

The net should for safety's sake be replaced every year.

MOVING THE TRAMPOLINE

If you need to move the trampoline, two people should be used. All connector points should be wrapped and secured with weather resistant tape, such as duct tape. This will keep the frame intact during the move and prevent the connector points from dislocating and separating. When moving, lift the trampoline slightly off the ground and keep it horizontal to the ground. For any type of other move, you should disassemble the trampoline.

Keep this instruction manual.



Samlevejledning Trampolin – Extreme 305

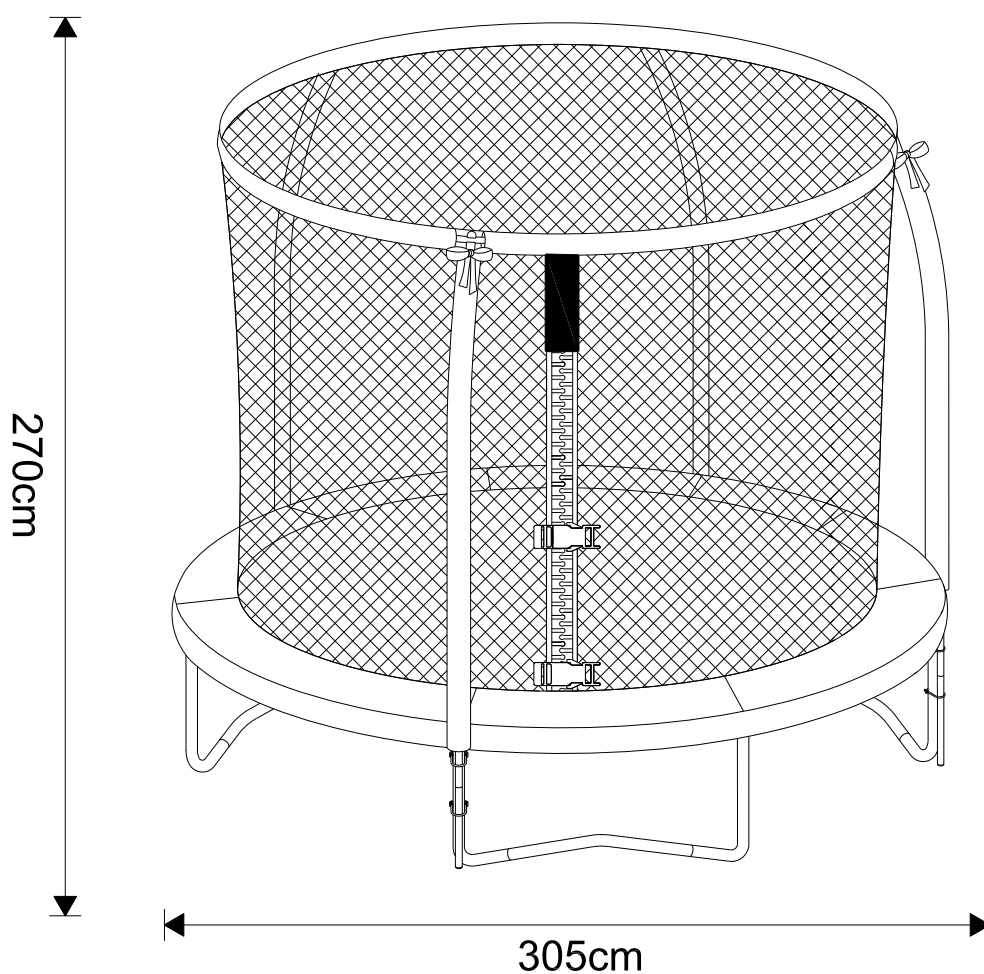

Det er meget vigtigt, at du læser og forstår vejledningen, før trampolinen samles og anvendes.

Vi håber, at du bliver glad for at bruge trampolinen. En trampolin er rigtig sjov og giver god motion på samme tid. Det tager lidt tid at samle den, men det er lettere, hvis du læser alle anvisninger, før du starter. Det kan tage over en time at samle trampolinen, så vær tålmodig, og få en til at hjælpe dig.

VIGTIGT

Læs følgende erklæring og advarsler for at undgå alvorlige eller fatale ulykker.

Advarsel.

- Maks. 150 kg.
- Kun til privat brug.
- Til udendørs brug.
- Kun en bruger ad gangen. Risiko for kollision.
- Nettet bør udskiftes hvert år.
- Opsyn af en voksen er påkrævet.
- Lav ikke saltomortaler. Det er meget farligt, og du risikerer alvorlige skader eller dødsfald.
- Luk altid sikkerhedsnettets åbning, inden du begynder at hoppe.
- Læs vejledningen.
- Trampolinen skal samles af en voksen ifølge samlevejledningen og derefter tjekkes før brug.
- Hop kun i gymnastiksko eller med bare fødder.
- Tøm lommerne, og hav ikke noget i hænderne.
- Hop altid på midten af dugen.
- Må ikke bruges, hvis dugen er våd.
- Spis ikke, når du hopper
- Hop aldrig ned fra trampolinen.
- Benyt trampolinen i begrænset tid (hold jævnlige pauser).
- Må ikke bruges i stærk blæst. Fastgør trampolinen.
- Forsøg ikke at springe over nettet.
- Hop ikke ind i nettet med vilje.
- Forsøg ikke at hoppe tilbage fra nettet igen med vilje.
- Hæng ikke oven på nettet, og forsøg ikke at klatre op i det.
- Tag smykker af, som kan vikles ind i nettet eller skære i det.

Placering af trampolinen

Placer aldrig trampolinen på et cementgulv eller andre hårde flader. Den bedste placering er på en jævn og stabil overflade som for eksempel en græsplæne. Der skal være et frit område på mindst to meter omkring trampolinen. Sørg for, at der ikke er nogen ledninger, grene, hegn eller andre mulige farer over og rundt om trampolinen. Trampolinen må ikke placeres tæt på pools, gynger, rutsjebaner, klatrestativer eller andre installationer, der udgør en risiko. Denne trampolin er ikke beregnet til nedgravning.

Vejrforhold

Trampolinen må ikke bruges, når den er våd. Skil trampolinen ad om vinteren, og opbevar alle stofdele (dug, skumkanter og sikkerhedsnet) indendørs. Fjern skumkanter og sikkerhedsnet ved stærk blæst, og fastgør trampolinen til jorden med pløkker/jordspyd (sælges separat).

Vejledning

Start langsomt. Forsøg ikke at lave svære øvelser.

Hop ikke i trampolinen, når du er træt. Det øger risikoen for skader. Sørg for at bære passende fodtøj, f.eks. gymnastiksko, eller hop med bare fødder.

Træd aldrig på sikkerhedsbetrækket. Det er ikke konstrueret til at kunne bære en persons vægt. Når du skal ned fra trampolinen, må du aldrig hoppe. Kravl altid af. Hop aldrig i trampolinen, hvis du har indtaget stoffer eller alkohol.

Der skal altid være andre til stede, når du hopper i trampolinen. Så er der nogen til at hjælpe dig, hvis du skulle komme til skade.

Begynd altid med at hoppe midt i cirklen. Hvis du lander mere end 30 cm fra kanten af logoet, skal du omgående holde op med at hoppe!











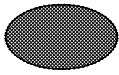
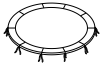

Begynd at hoppe på midten af dugen igen.

Montering





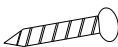





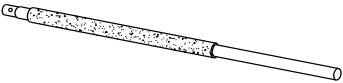

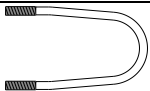

Læs samlevejledningen omhyggeligt, før du begynder at samle trampolinen. Det kan anbefales, at to personer hjælpes ad med at samle trampolinen.

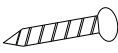
Begynd med at kontrollere, at du har alle de nødvendige dele. Hver dels referencenummer vil blive brugt her i vejledningen som en hjælp til dig.

Øversigt over dele (trampolin)

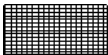
Delnr.	Dele	Beskrivelse	Antal
1		Trampolindug med påsyede trekantringe	1
2		Sikkerhedsbetræk	1
3		Topramme med benfæster	4
4		Topramme med benfæster	4
5		Benbase	4
6		L-formet ben	8
7		Galvaniserede fjedre (3,2mm x 28N)	56
8		Fjedermonteringsværktøj	1
9		Buet spændeskive	8
10		Skrue	8
11		Unbrakonøgle	1
12		Fjederskive (stor)	8
13		Selvlåsende skrue	8
14		Fjederskive (lille)	8

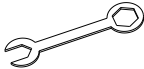
Oversigt over dele (sikkerhedsnet)

Delnr.	Dele	Beskrivelse	Antal
A		Øvre rammerør med langt skumstykke	4
B		Midterste rammerør med kort skumstykke	4
C		Nedre rammerør uden skumstykke	4
D		U-skrue	8
E		Spændebånd	8
F		Låsemøtrik	16
G		Afstandsstykke	8
H		Selvlåsende skrue	12
I		Kabeltråd	8
J		Fjederskive (lille)	8
K		Plastikhætte	4
L		Kasket	4
M		Sikkerhedsnet	1
N		Line	6
O		Endestykke	4
P		Skruenøgle	1
Q		PVC-muffe	4

Montering af trampolin

Der skal to personer til at montere trampolinen.

Trin 1

Start med at bygge rammen. Skub delene sammen. Begynd med at lægge delene ud som vist på billedet.

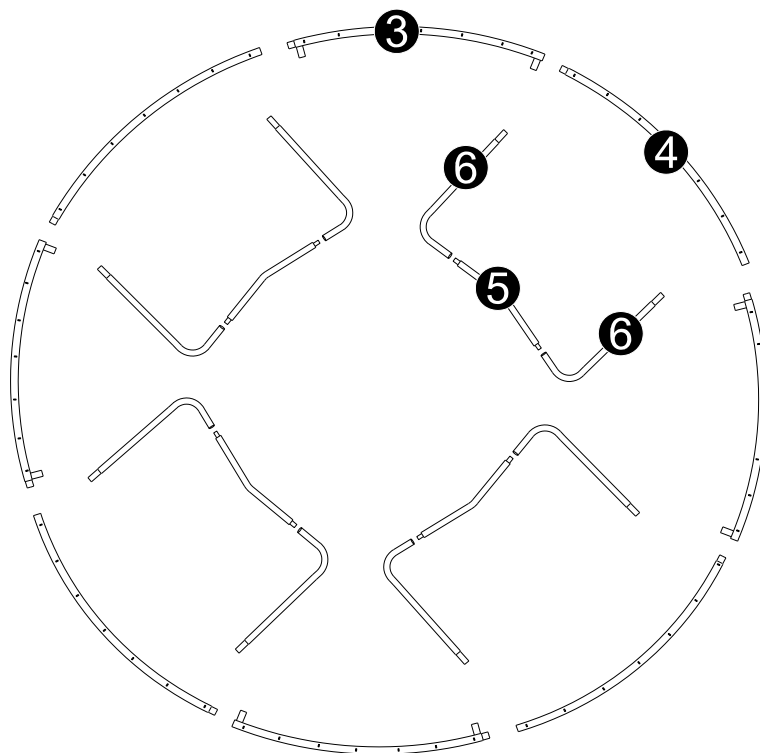

Trin 2

Før to L-formede ben 6 ind i benbasen 5 som vist. Gentag for alle benbaserne. Stram med Skruen 10, Fjederskive (stor) 12 og den buede spændeskive 9.

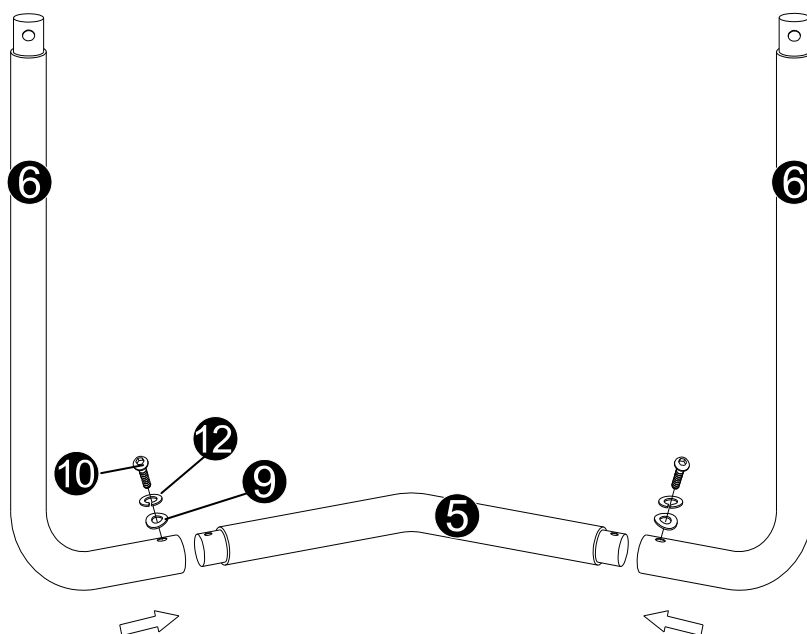

Trin 3

Tag den benstøtte, som du samlede i trin 2. Her er det lettest, hvis en person holder benstøtten, og en anden person sætter topprammen med benfæster" ③ på plads som vist på billedet. Gentag dette for alle ben.

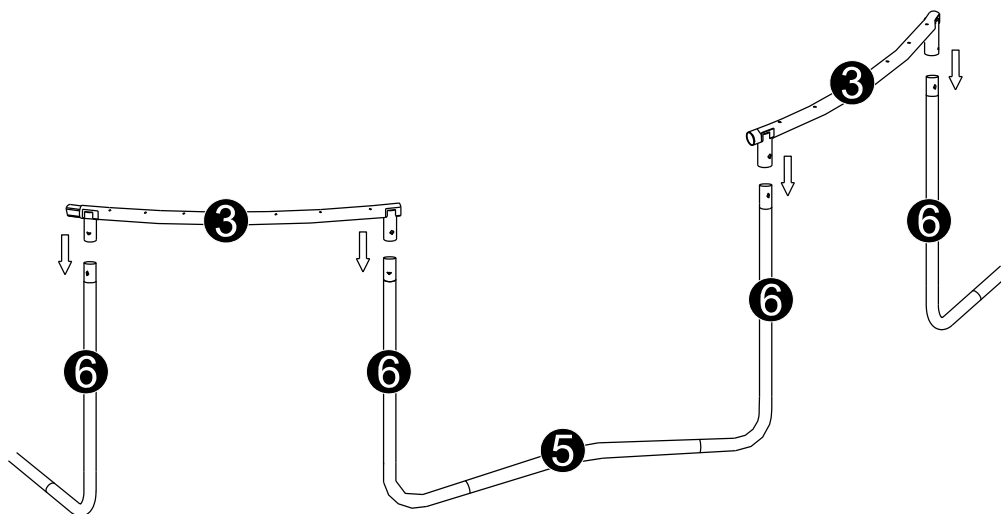

Indsæt nu de resterende topprammer ④ i hullerne mellem benstøtterne som vist.

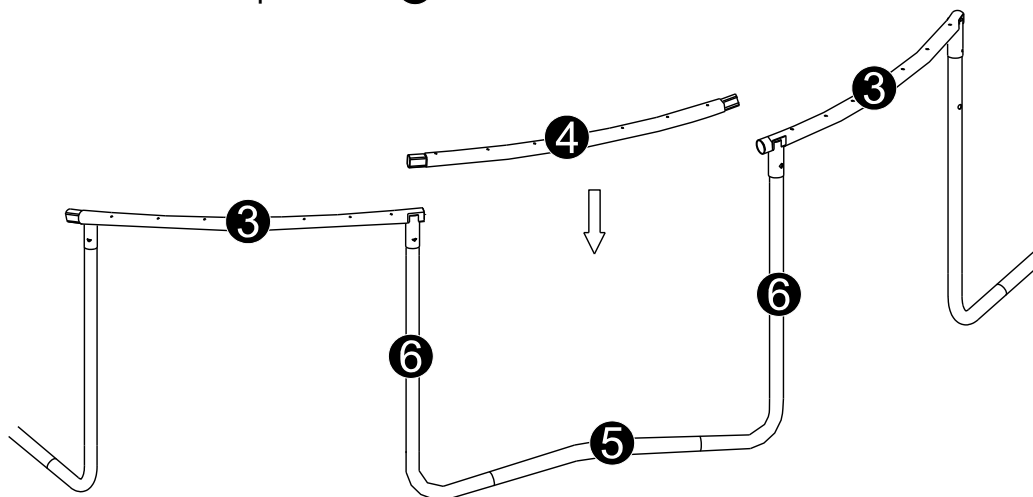

Skrue den selvvlåsende skrue ⑬ og Fjederskive (lille) ⑭ på som vist. Stram dem ikke på nuværende tidspunkt.

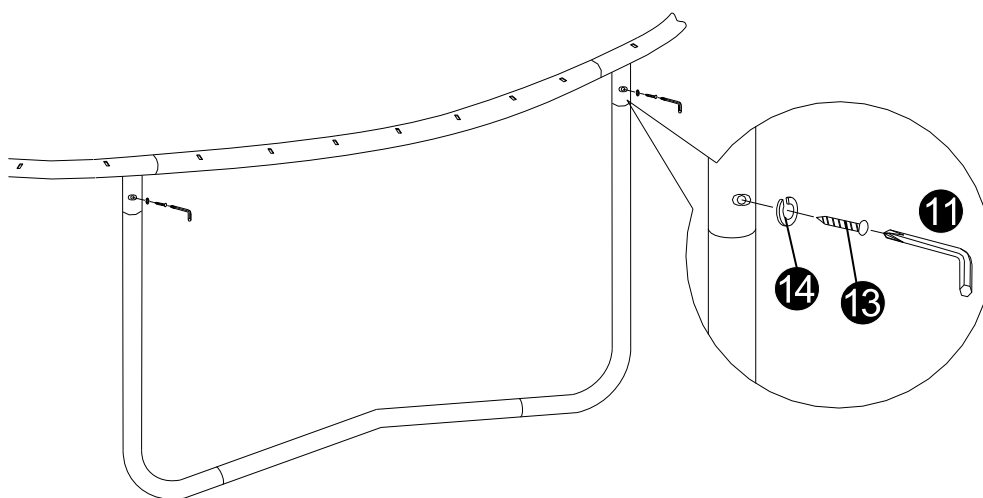

Trin 4

Vær forsigtig, når fjedrene skal monteres.

Start med at lægge trampolindugen ① ud inde i rammen.

Vælg et startpunkt. Kald dette "punkt 1". Brug det specielle fjedermonteringsværktøj til at sætte fjedrene med R-krog ⑦ fast som vist på billedet.

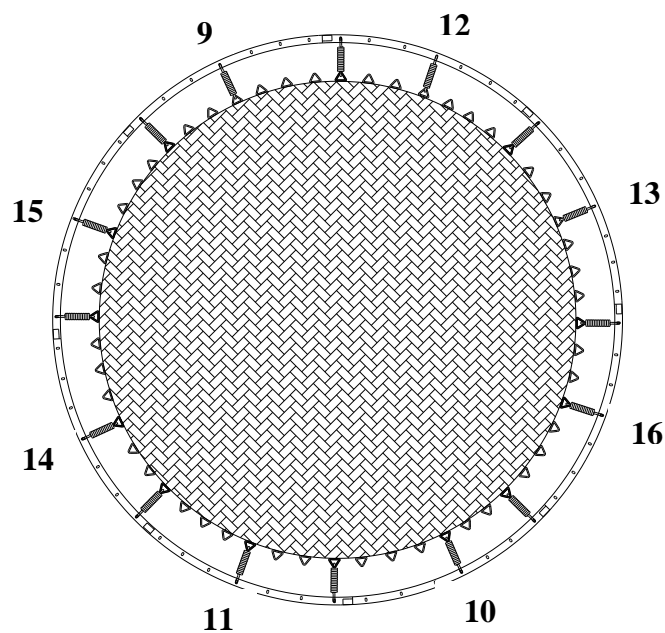
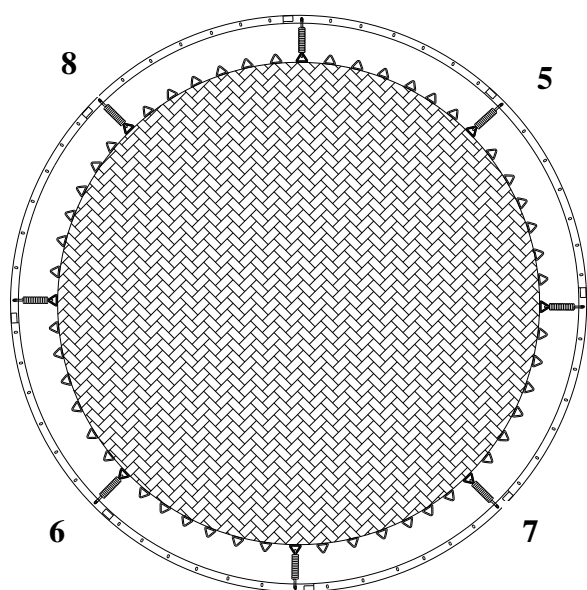
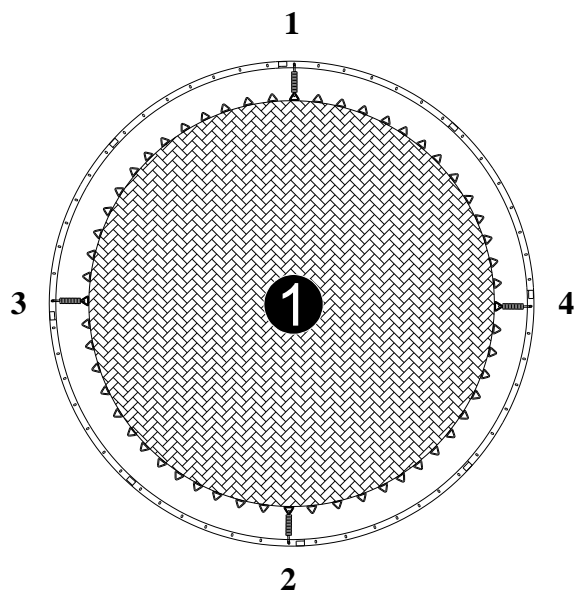
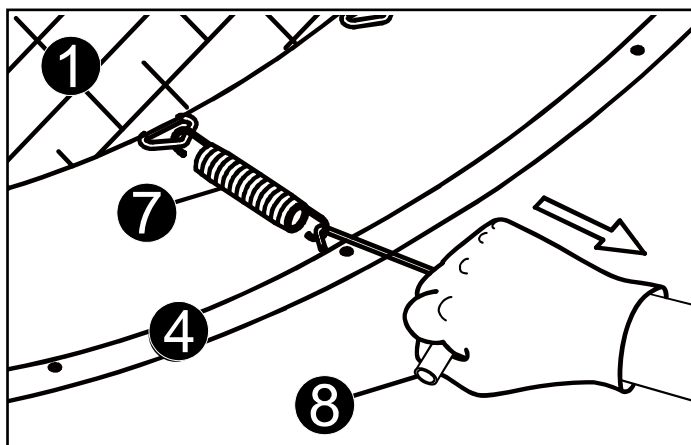

Begynd med at sætte fjederens krog ind i den V-formede ring på trampolindugen. Brug derefter fjedermonteringsværktøjet til at trække fjederen på plads på rammen. Sørg for, at fjederen sidder ordentligt fast, ellers kan den løsne sig, når du hopper i trampolinen. Du bør have beskyttelseshandsker på for at undgå at komme til skade.

Når den første fjeder er på plads, skal du fortsætte i numerisk rækkefølge som vist på billedet. Når du er færdig med nummer 16, kan du fastgøre de resterende fjedre i tilfældig rækkefølge. Det er vigtigt at følge vejledningen nøje for at få spændt trampolindugen korrekt. Hvis du ikke følger dette mønster, vil det blive meget svært at montere trampolindugen korrekt.

Trin 5

Læg sikkerhedsbetrækket ② over trampolinen, så det dækker fjedrene og metalrammen. Læg stropperne, så der ligger en over benfæsterne og en imellem. Sørg for at stramme stropperne godt. Stram stropperne som vist.

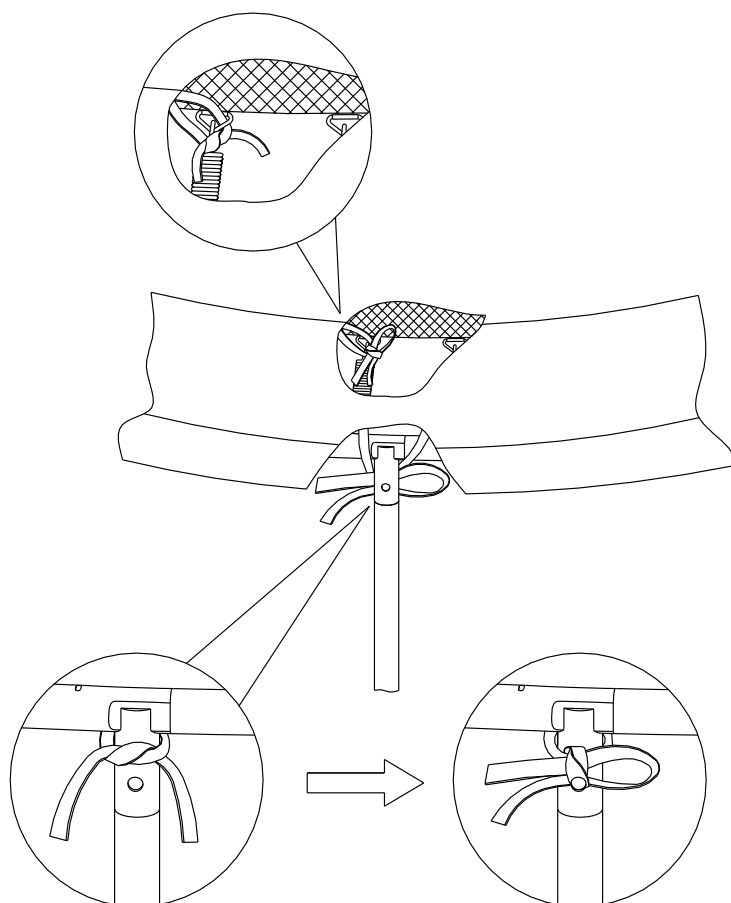
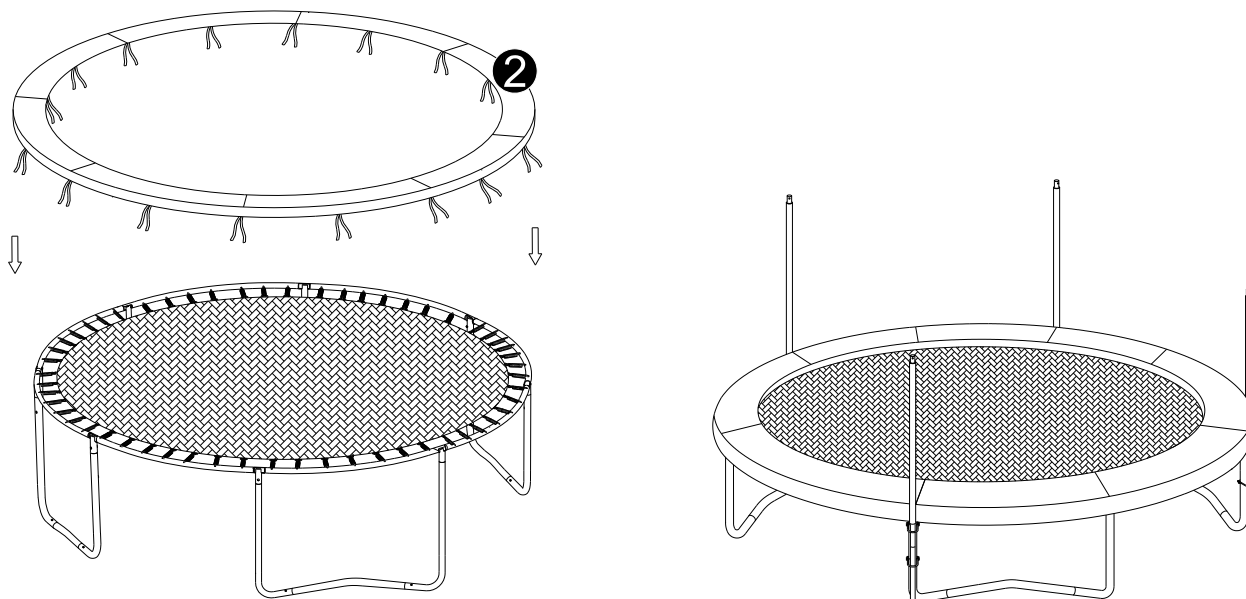

Nu skal du stramme alle skruerne grundigt på trampolinen.

Montering af sikkerhedsnet

Der skal to personer til at montere trampolinen.

Trin 6

Sæt endestykket **C** fast på det nedre rammerør uden skumstykke **C**, og sørg for, at det sidder korrekt som vist.

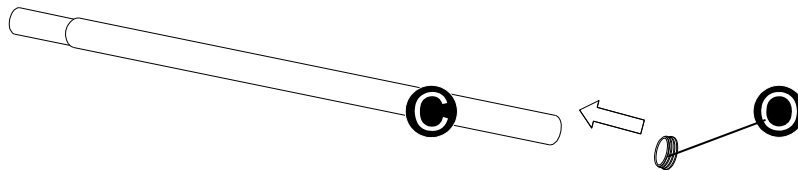

Sæt det nedre rammerør uden skumstykke **C** fast på benrammen med U-skruen **D**, afstandsstykket **G**, og fastgør det med spændebåndet **E** og låsemøtrikken **F** som vist.

Tip: Stram ikke alle låsemøtrikkerne på en gang. Stram dem, når trin 7 er færdig.

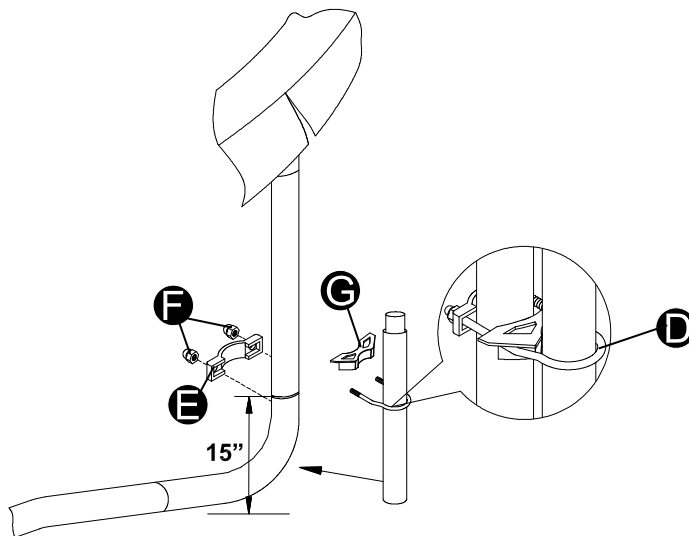

Trin 7

Sæt det midterste rammerør med skumstykke **B** fast på det nedre rammerør uden skumstykke **C**. Skru den selvlåsende skrue **H** og Fjederskive (lille) **J** i som vist. Stram dem ikke på nuværende tidspunkt..

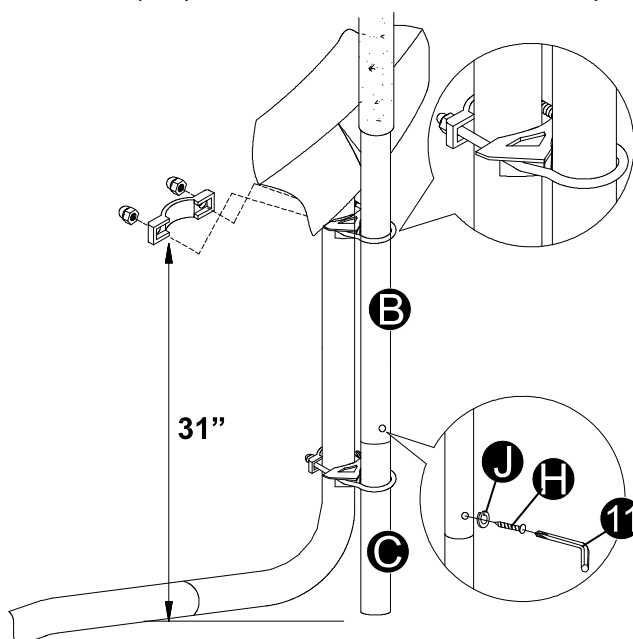

Gentag trin 1 og 2 for alle rammerørspær, og stram møtrikkerne.

Trin 8

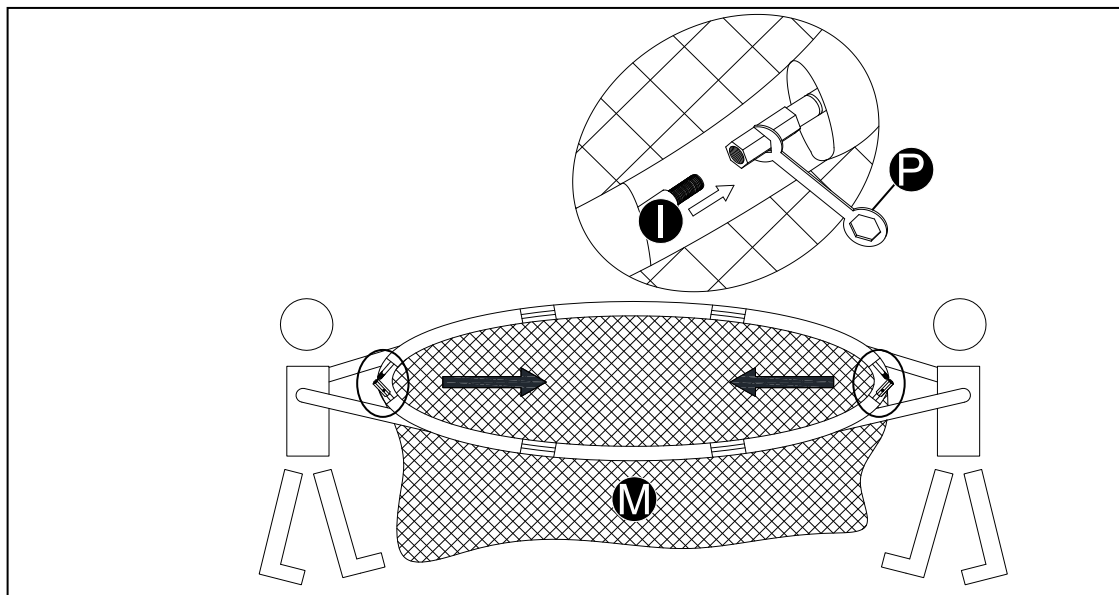
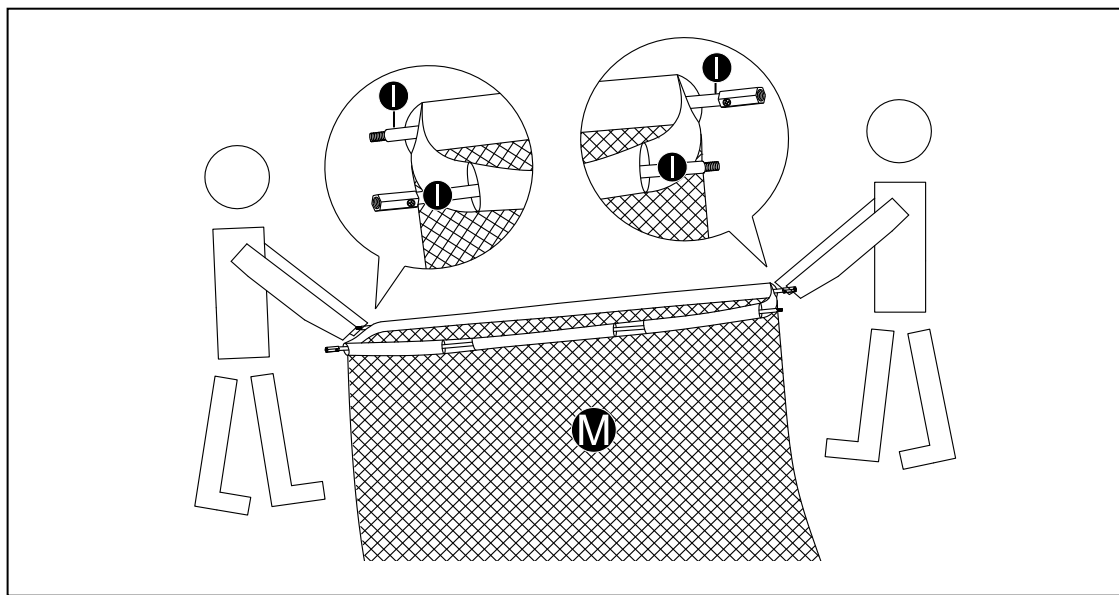
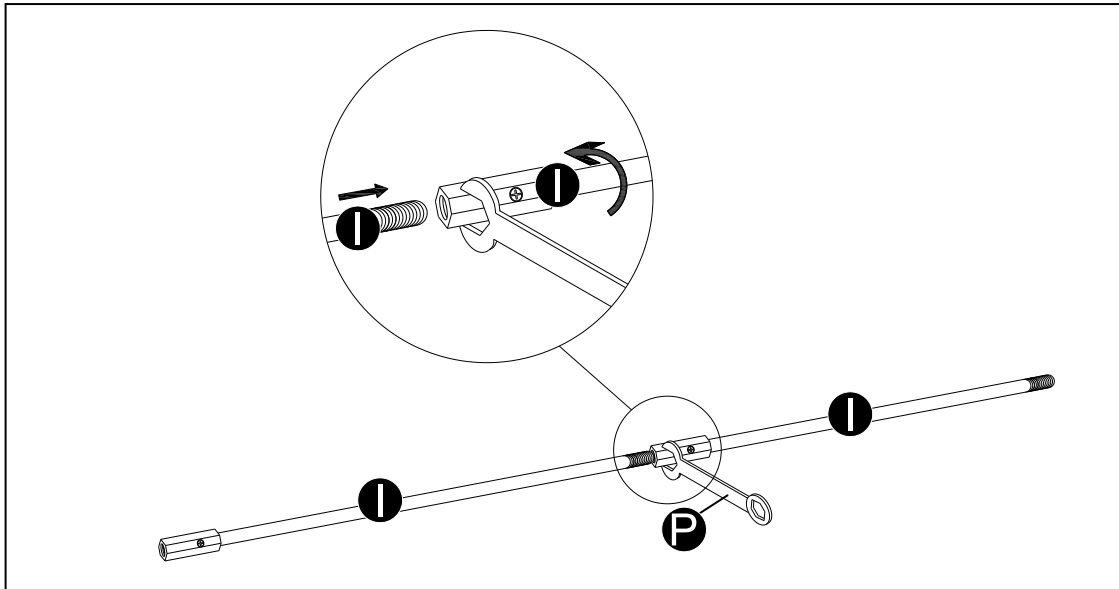

Trin 9

Træk skummet lidt væk for at finde hullet i den kurvede ende af det øvre rammerør med Skumstykke **A** .
Sæt plastikhætten **K** på, og fastgør den med den selvslåsende skrue **H** .
Skub pvc-muffen **Q** ind i det øvre rammerør med langt skumstykke **A** . Sørg for, at stroppen på den øverste del af muffen sidder øverst. Fastgør det øverste hul på muffen med en strop.
Før derefter kabeltråden ind i plastikhætten **K** , der sidder på det øvre rammerør med langt skumstykke **A** .
Sørg for, at kabeltråden sidder korrekt i åbningen. Træk pvc-muffen **Q** ned for at dække hele skumstykke som vist.
Sæt til sidst hættens **L** på plastikhætten **K** .
Gentag for alle rør.

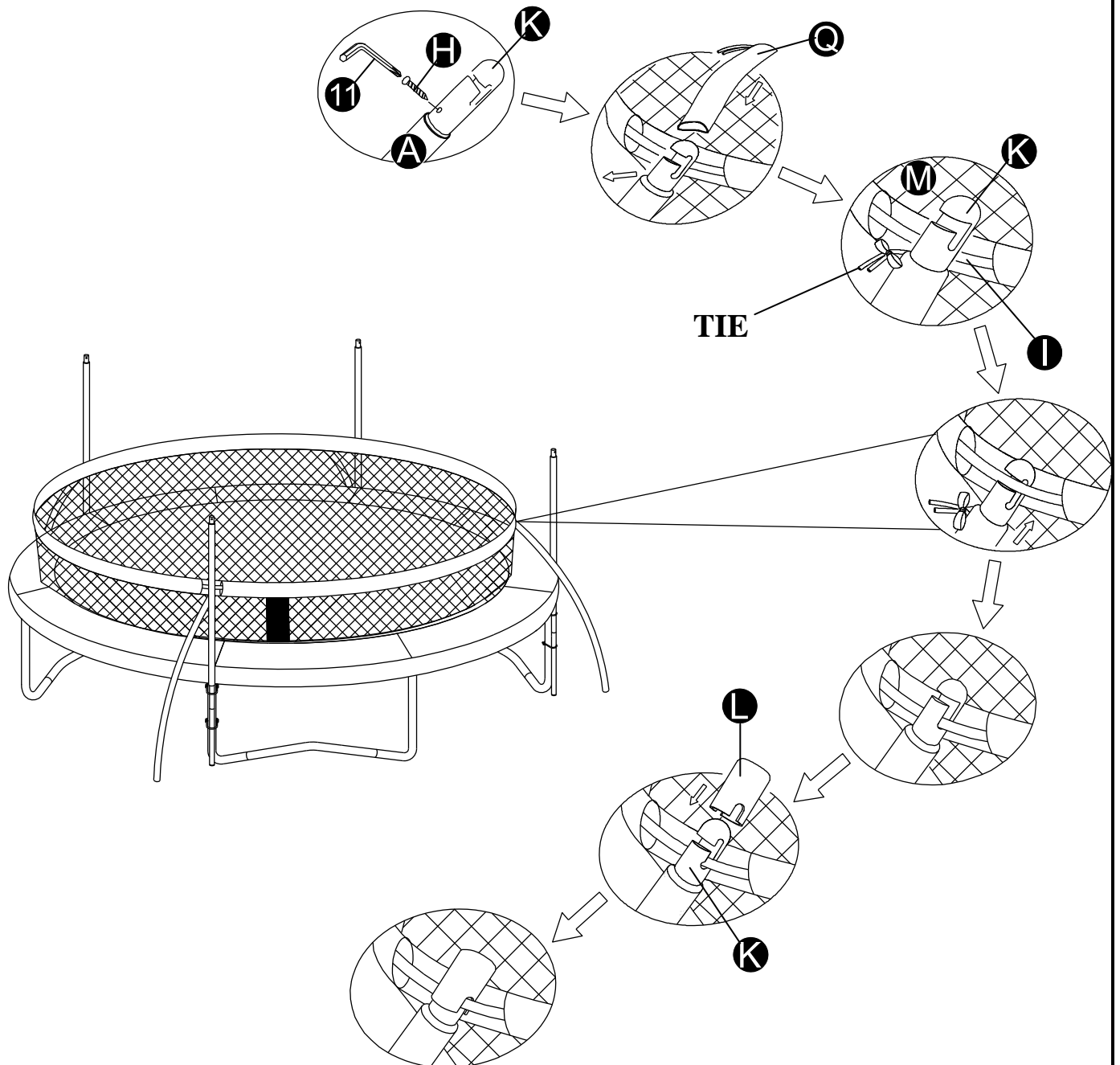

Trin 10

Løft nu den samlede ring op for at sætte det øvre rammerør med langt skumstykke **A** fast på det midterste rammerør med kort skumstykke **B**.

Sørg for, at alle ben sidder fast, før du fastgør dem med den selvslåsende skrue **H** og Fjederskive (lille) **J**.

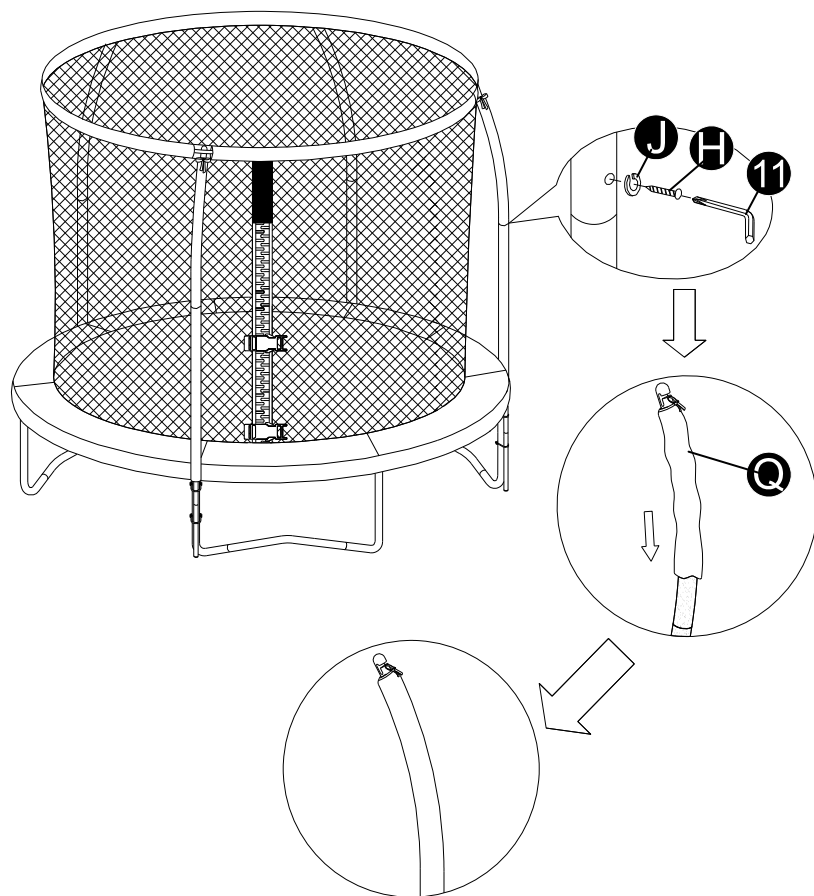
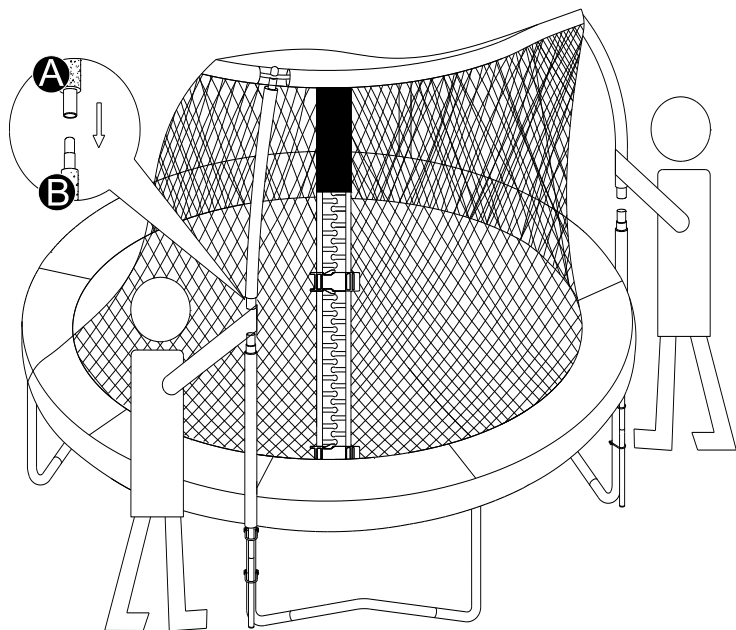

Trin 11

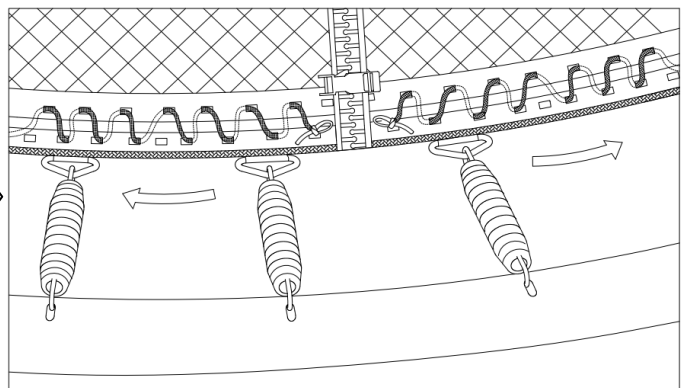
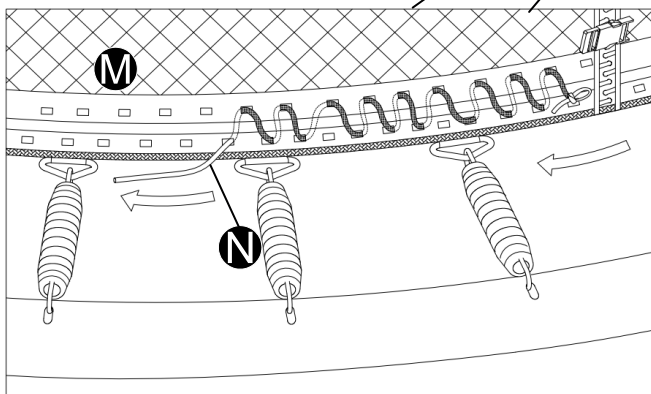
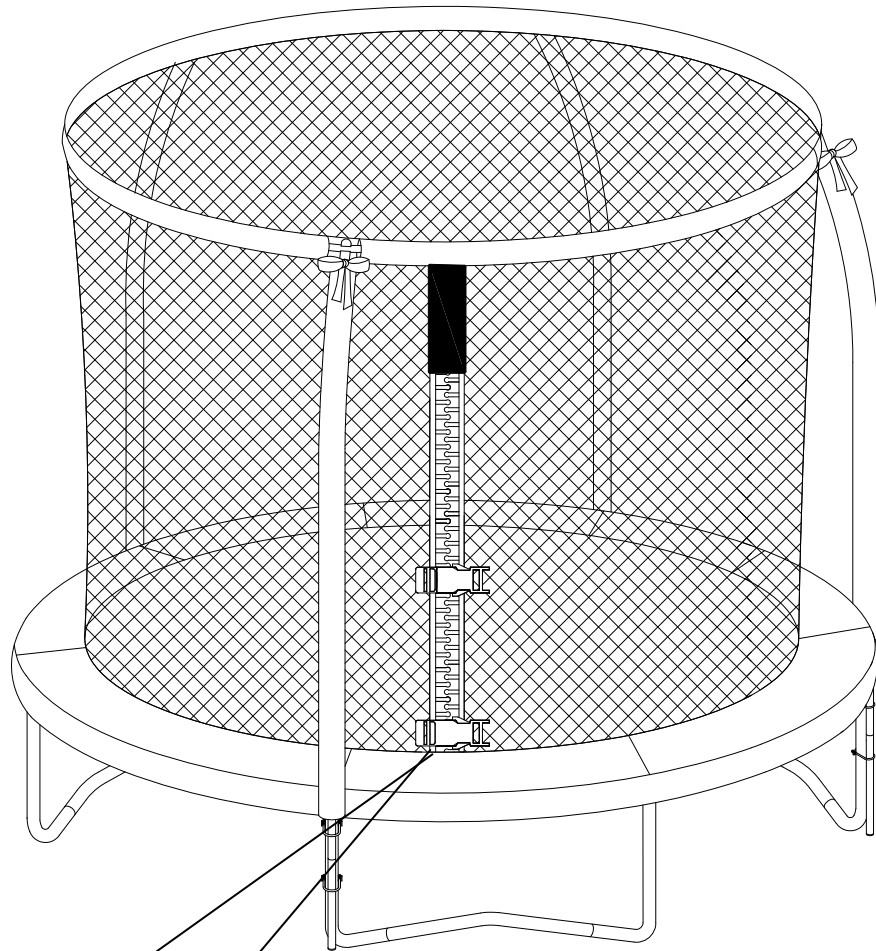

Trin 12

Træk i sikkerhedsnettets  lynlås ved indgangen til trampolinen. Indgangen skal være placeret mellem to af trampolinens ben. Spænd så to spændere som vist.

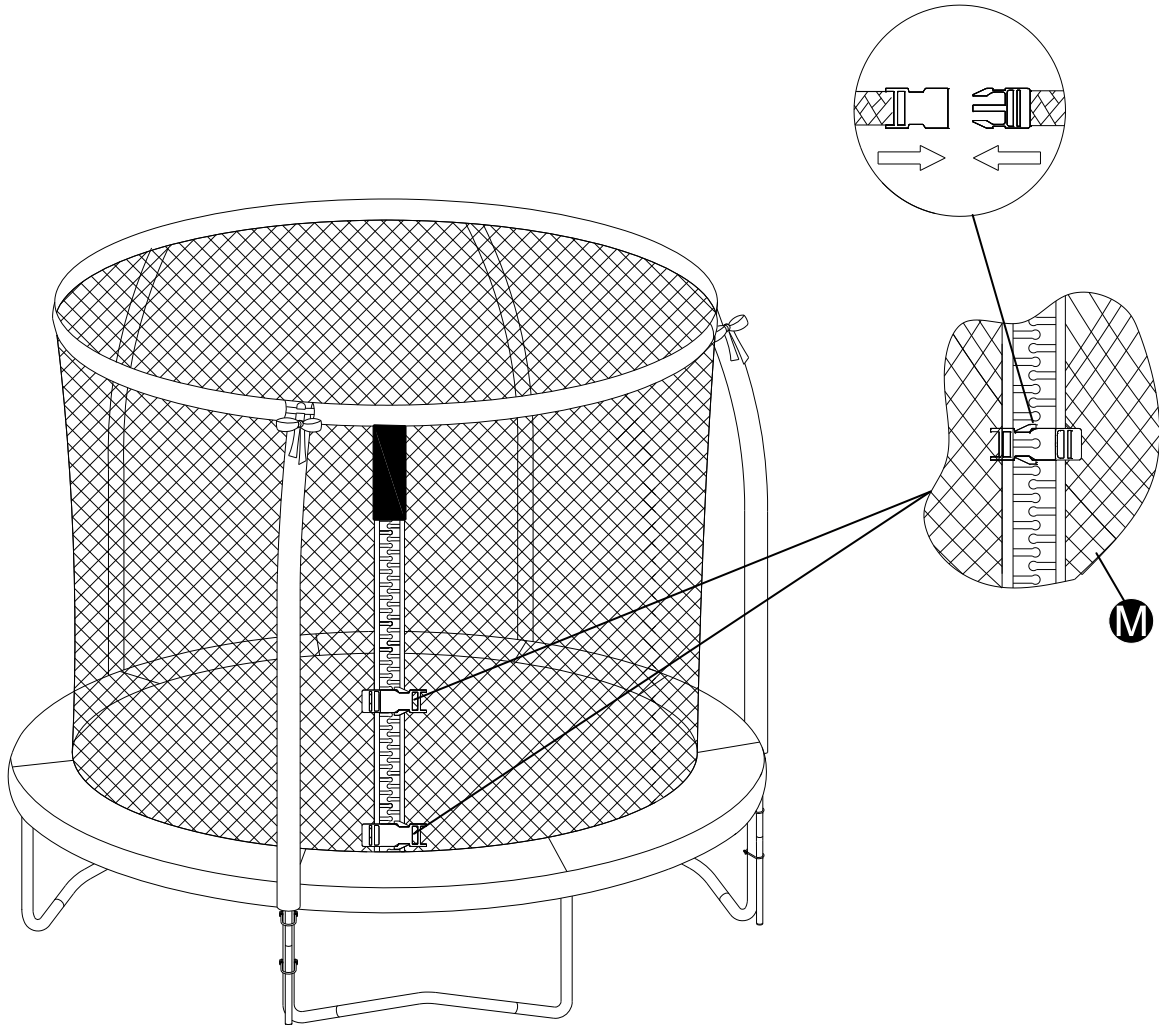

Trin 13

Vigtigt: Husk at stramme alle skruer, møtrikker og spændere på både trampolin og sikkerhedsnet. Hvis ikke dette gøres, kan det ske, at den ikke fungerer korrekt, hvilket kan føre til skader, der ellers kunne have været undgået.

Trampolinen er nu færdigmonteret. Husk at være forsigtig, når du hopper.

GRUNDLÆGGENDE TRAMPOLINHOP

GRUNDLÆGGENDE HOP

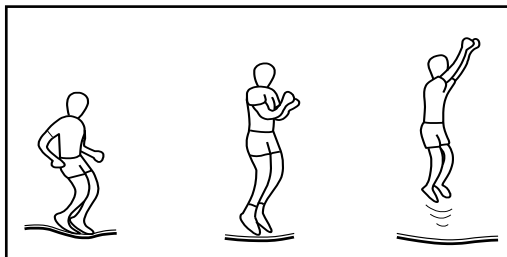

1. Start fra oprejst position, stå med spredte ben og hovedet oppe og med øjnene på rampolindugen.
2. Sving armene fremad og op og rundt i en cirkulær bevægelse.
3. Saml fødderne, når du er oppe i luften, og lad dine tæer vende nedad.
4. Hold fødderne fra hinanden, når du lander på dugen.

HOP PÅ KNÆ

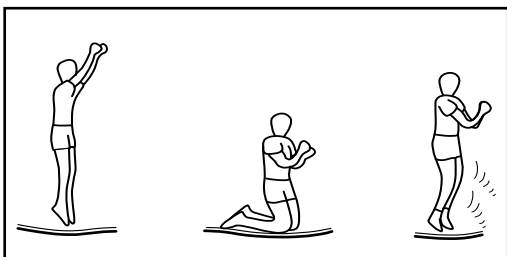

1. Start med lave basishop.
2. Land på knæene, samtidig med at du holder ryggen lige og kroppen strakt, og brug dine arme til at holde balancen.
3. Hop basishop igen ved at svinge armene opad.

HOP PÅ NUMSEN

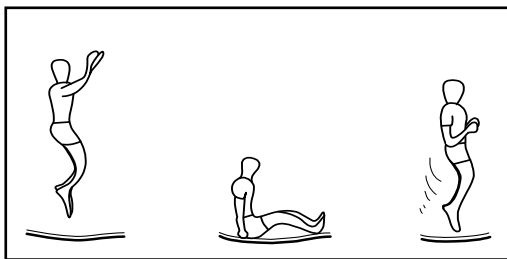

1. Land i siddende stilling.
2. Anbring hænderne på dugen ud for hofterne, lås ikke dine albuer.
3. Hop tilbage til oprejst stilling, skub fra med hænderne.

FORLÆNS HOP

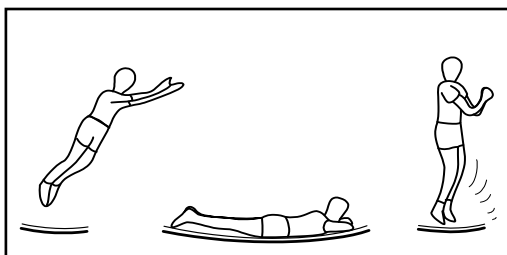

1. Start med at hoppe lavt.
2. Land liggende udstrakt på maven, og hold hænder og arme fremad på dugen.
3. Skub fra på dugen med armene for at returnere til stående stilling.

180-GRADERS HOP

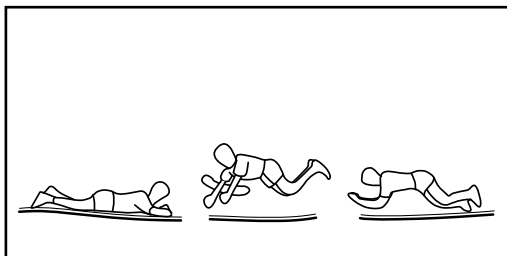

1. Start med at hoppe forlæns.
2. Skub fra med venstre eller højre hånd og arme (afhængigt af, hvilken vej du ønsker at dreje).
3. Hold hoved og skuldre i samme retning, og hold din ryg parallelt med dugen og hovedet oppe.
4. Land liggende udstrakt på maven, og returnér til stående position ved at skubbe opad med hænder og arme.

ADVARSEL!

BEGYND ALTID MED AT HOPPE PÅ MIDTEN AF DUGEN. HVIS DU LANDER MERE END 30 CM FRA LOGOET, SKAL DU STRAKS STOPPE!
BEGYND AT HOPPE IGEN PÅ MIDTEN AF DUGEN.

BEMÆRK

SØRG FOR, AT ALLE SPÆNDER OG LYNLÅSE ER LUKKET KORREKT, NÅR TRAMPOLINEN BRUGES.

PLEJE OG VEDLIGEHOLDELSE

Trampolinen er designet og fremstillet af kvalitetsmaterialer og udsøgt håndværk. Ved korrekt vedligeholdelse vil den give brugerne mange års træning, sjov og glæde, samtidig med at risikoen for skader vil være mindre. Følg vejledningen nedenfor. Montering af yderligere tilbehør bør ske i henhold til leverandørens vejledning.

Trampolinen er designet til at kunne tåle en bestemt vægt og belastning. Sørg for, at kun én person bruger trampolinen ad gangen. Brugere bør enten bruge strømper, gymnastiksko eller hoppe i bare fødder, når de bruger trampolinen. Udendørssko eller sportssko bør IKKE bæres, når trampolinen bruges. For at undgå beskadigelse eller huller i trampolindugen bør kæledyr ikke træde på dugen. Brugere skal også fjerne skarpe genstande, som de måtte have på sig, før de bruger trampolinen. Der bør ikke medtages nogen former for skarpe eller spidse genstande, når trampolinen bruges. Tjek med jævne mellemrum, at skruer, møtrikker og bolte er strammet godt, da de vil løsne sig under brug. Sørg for, at alle fjederbelastede samlinger (fjederpinde) er intakte og ikke kan løsne sig under brug. Tjek alle beskyttelsesdele for skarpe kanter, og erstat dem, hvis det er nødvendigt. Sørg for, at dug, skumkanter og tilbehør ikke er defekte.

Undersøg altid trampolinen for slitage, forkert brug eller manglende dele før brug. Der kan opstå en række situationer, der kan øge din risiko for at komme til skade. Vær opmærksom på:

- revner eller huller i trampolindugen
- sunket trampolindug
- løse sting eller andre former for ødelæggelse af dugen
- bukkede eller knækkede rammedele, f.eks. på trampolinens ben
- ødelagte, manglende eller beskadigede fjedre
- ødelagte, manglende eller forkert monteret sikkerhedsbetræk
- fremspring af enhver art (især skarpe) på rammen, fjedre eller dugen

Bemærk. Sol, regn, sne og ekstreme temperaturer nedsætter delenes holdbarhed.

HVIS DU MENER, AT DISSE FORHOLD ELLER ANDET KUNNE FORÅRSAGE PERSONSKADE FOR BRUGERNE, BØR TRAMPOLINEN SKILLES AD ELLER SIKRES MOD BRUG, INDTIL FEJLEN(E) ER BLEVET UDBEDRET.

Foretag ikke ændringer af trampolinen eller nogen af delene

Af sikkerhedshensyn bør sikkerhedsnettet udskiftes hvert år

FLYTNING AF TRAMPOLINEN

Det kræver to personer at flytte trampolinen. Alle fæstningspunkter bør være sikret med vejrbestandig tape, såsom klæbetape. Dette vil holde rammen intakt, når den flyttes, og forhindre, at fastgørelsespunkterne ikke flytter sig eller går løs. Løft trampolinen lidt fra jorden for at flytte den, og hold den vandret med jorden. Trampolinen bør skilles ad ved al anden form for flytning.

Gem denne vejledning.